

HEC

Standard Bale Elevator

Owner's and Operator's Manual

Read and Understand this manual
Before Operating

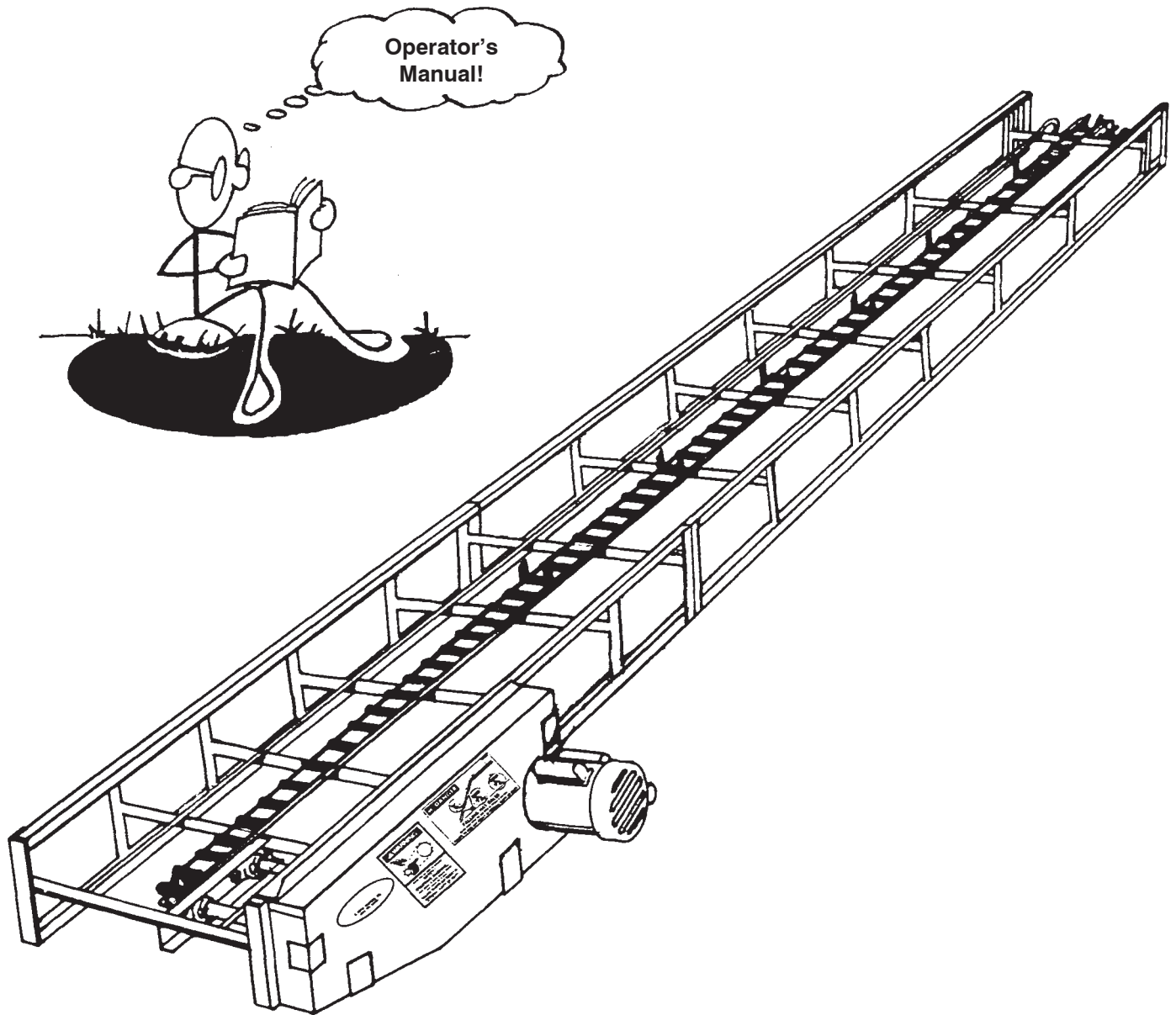

Additional Assistance

If any items covered in this manual are not fully understood by you, contact Cashmans for assistance:
(740) 363-6073

www.cashmans.com

General Safety Statement

It is your responsibility as an owner, operator or supervisor to know what specific requirements, precautions and work hazards exist and to make these known to all other personnel working with the equipment or in the area, so that they too may take any necessary safety precautions that may be required. Failure to read this Owner's and Operator's Manual and its safety instructions is a misuse of the equipment.

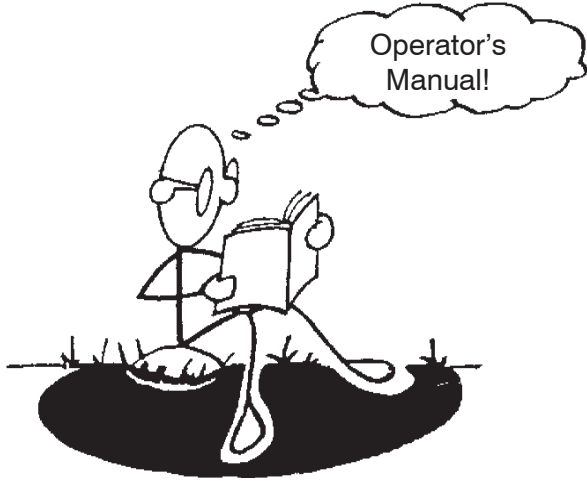

The Operator's Manual



Anyone who will operate or work around an elevator or transport shall first read the Owner's and Operator's Manual!

Complete sign-off sheet in "Operator Qualifications" section of this Manual to document training.



Safety Alert Symbol

This Safety Symbol means:

**Attention!
Become Alert!
Your Safety Is Involved!**

The Safety Alert Symbol identifies important safety messages on machines, safety decals, in manuals, or elsewhere. When you see this symbol, be alert to the possibility of personal injury or death. Follow the instructions in the safety message.

This symbol will be used with one of three signal words: **CAUTION** **WARNING** **DANGER** to indicate the degree of hazard.

CAUTION — Hazards or unsafe practices which **COULD** result in minor personal injury or product or property damage.

WARNING — Hazards or unsafe practices which **COULD** result in severe personal injury or death.

DANGER — Immediate hazards which **WILL** result in severe personal injury or death.

Why is Safety important to You?

3 Big Reasons:

- Accidents Disable and Kill
- Accidents Cost
- Accidents Can Be Avoided

Foreword

This Manual is intended to point out some of the basic situations which may be encountered during the normal operation and service of your machine and to suggest possible ways of dealing with these conditions.

Additional precautions may be necessary, depending on conditions at the worksite or in the service area. The manufacturer has no direct control over machine application, operation, inspection, lubrication, or maintenance. Therefore, it is your responsibility to use good safety practices in these areas.

Other information which may affect the safe operation of your machine may be contained on safety decals, or in insurance requirements; employer's safety programs; safety codes; and local, state/provincial, and federal laws, rules, and regulations.

If you require information not covered in this manual, contact
Cashmans 1646 US Hwy 42 North Delaware, OH 43015.
(740) 363-6073
www.cashmans.com

Table of Contents

General Safety Statement	Inside Front Cover
Foreword	1
Decal Location.....	3
Operator Qualifications and Sign Off Sheet	4
Operating Instructions	
Maximum Angle of Elevation for Various Bale Lengths	5
Machine Inspection.....	6,7
Winch Operating Instructions.....	8
Movement and Placement.....	9 - 11
Electric Motor Drive	12
Safety Lockouts and Horsepower Requirements	13
Work Area Diagram	14 - 15
Elevator Operation.....	16
Bale Kick-off Operation and Assembly	18 - 19
Elevator Shutdown.....	20
Optional Accessories.....	21
Trouble Shooting.....	22 - 28
Service and Maintenance	29
Operating Heights and General Dimensions	30, 31
Layout Guide	32, 33
Assembly Instructions.....	34 - 44
Serial No. and Model No. Plate Location Guide	Insert
Warranty	Inside Back Cover

The Decals Shown On This Page Must Be Displayed As Shown Below

FREE REPLACEMENTS ARE AVAILABLE UPON REQUEST

Contact T. R. Metal Crafters, Inc.; 312 E. Industrial Drive; P.O. Box 248; Loyal, WI 54446
(Call Toll Free 1-800-842-5349)

- Safety decals must be replaced if they are destroyed, missing, painted over, or can no longer be read.
- New equipment components installed during repair shall be equipped with the same safety decals that were affixed to the original components.
- Keep decals wiped clean at all times.

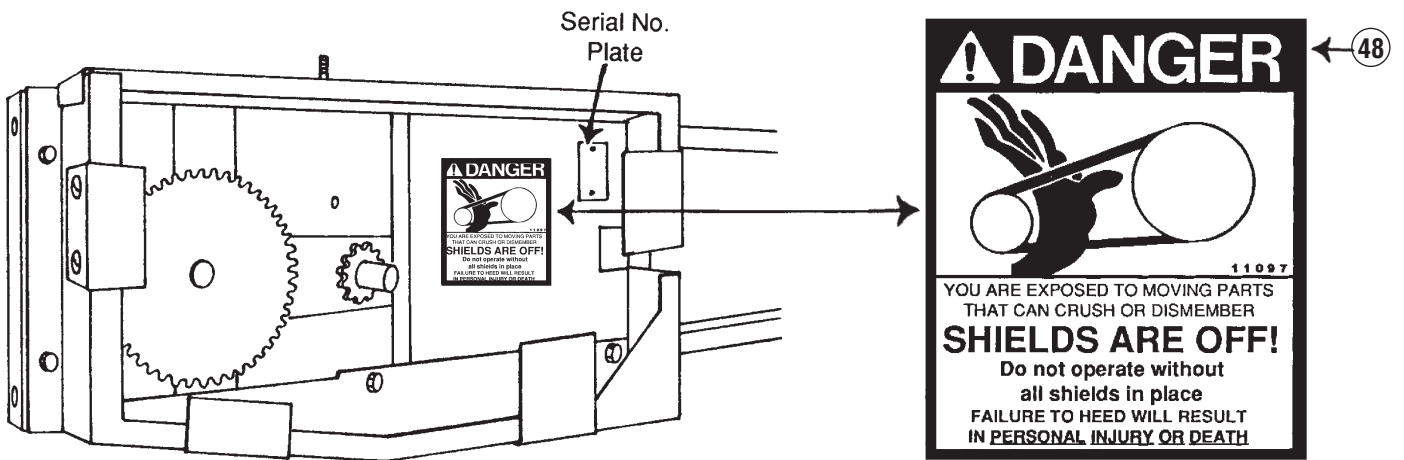
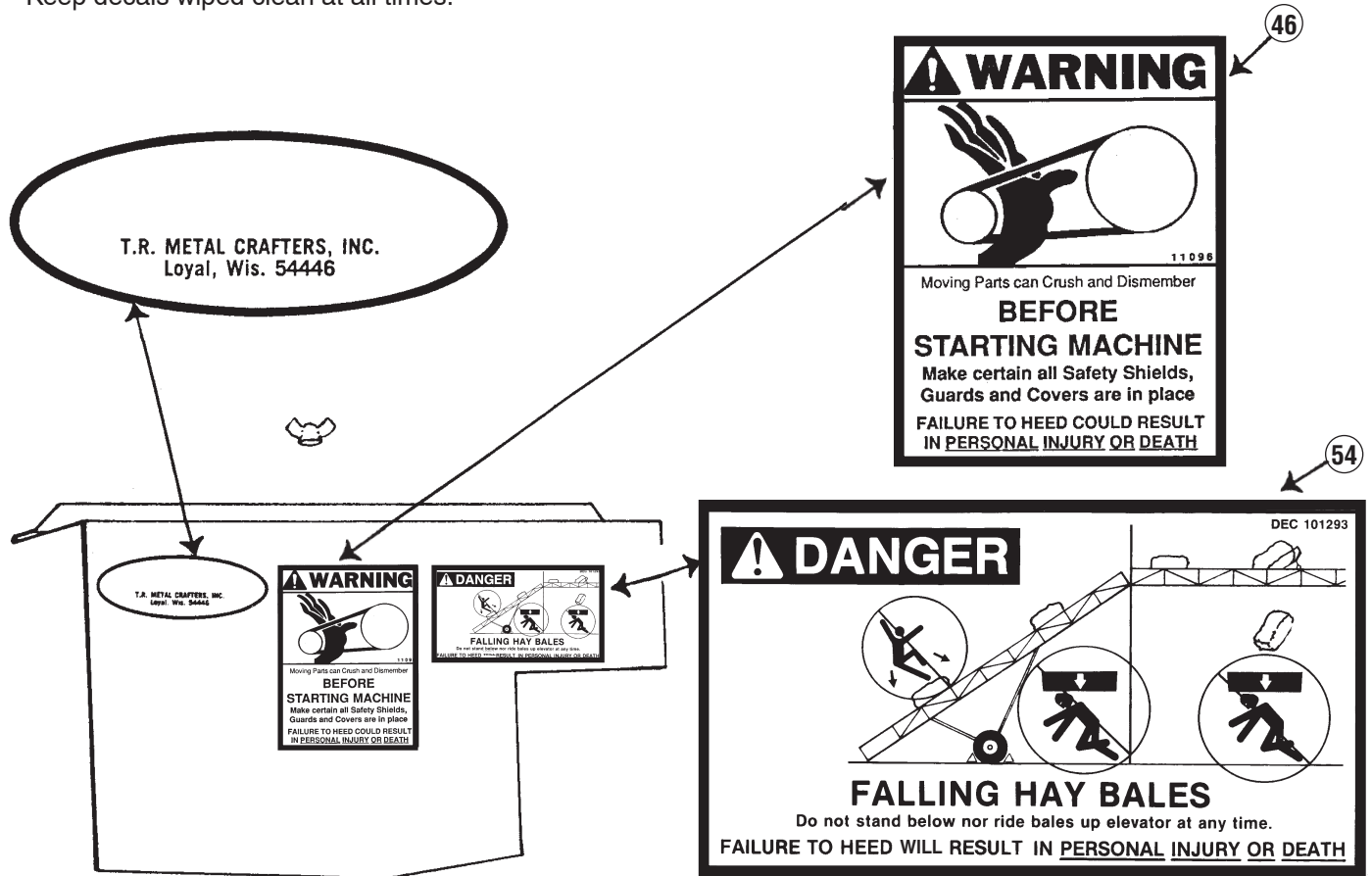

— refer to Parts List

4 Operator Qualifications and Sign Off Sheet

Operation of this machine shall be limited to competent and experienced persons. In addition, anyone who will operate or work around this machine must use good common sense. In order to be qualified, he must also know and meet all other requirements, such as:

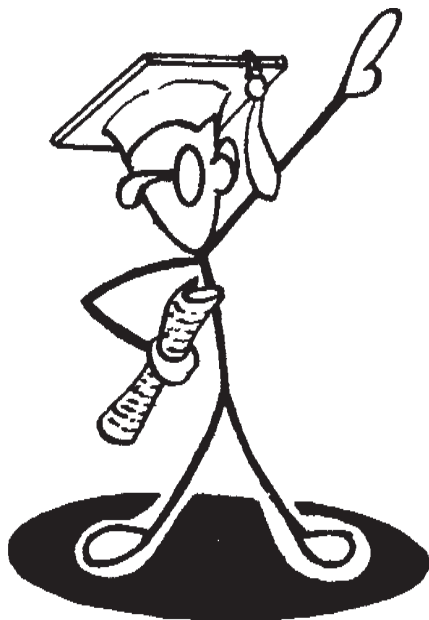

1. Some regulations specify that no one under the age of 18 may operate power machinery. This includes this machine. It is your responsibility to know what these regulations are in your own area or situation.
2. Current OSHA regulations state in part: "At the time of initial assignment and at least annually thereafter, the employer shall instruct **every** employee in safe operation and servicing of all equipment with which the employee is, or will be involved" (*per Federal Occupational Safety and Health Standards for Agriculture Subpart D, Section 1928.57 (a) (6)*)
3. Complete sign off sheet below to document training.
4. A person who has not read and understood all operating and safety instructions, is not qualified to operate this machine.
5. It is the responsibility of the owner, qualified operator/s or supervisor/s to see that no unqualified persons are allowed to operate this machine and that unqualified persons (*especially children*) stay out of the work area.



As a requirement of OSHA, it is necessary for the employer to train the employee in the safe operation and servicing of this machine at the time of initial assignment and at least annually thereafter. Use this sign off sheet to document training.

Date	Employer Signature	Employee Signature

Maximum Angle of Elevation for Various Bale Lengths

Bale Length	Maximum Elevation Angle
20"	30°
24"	35°
30"	40°
36"	45°

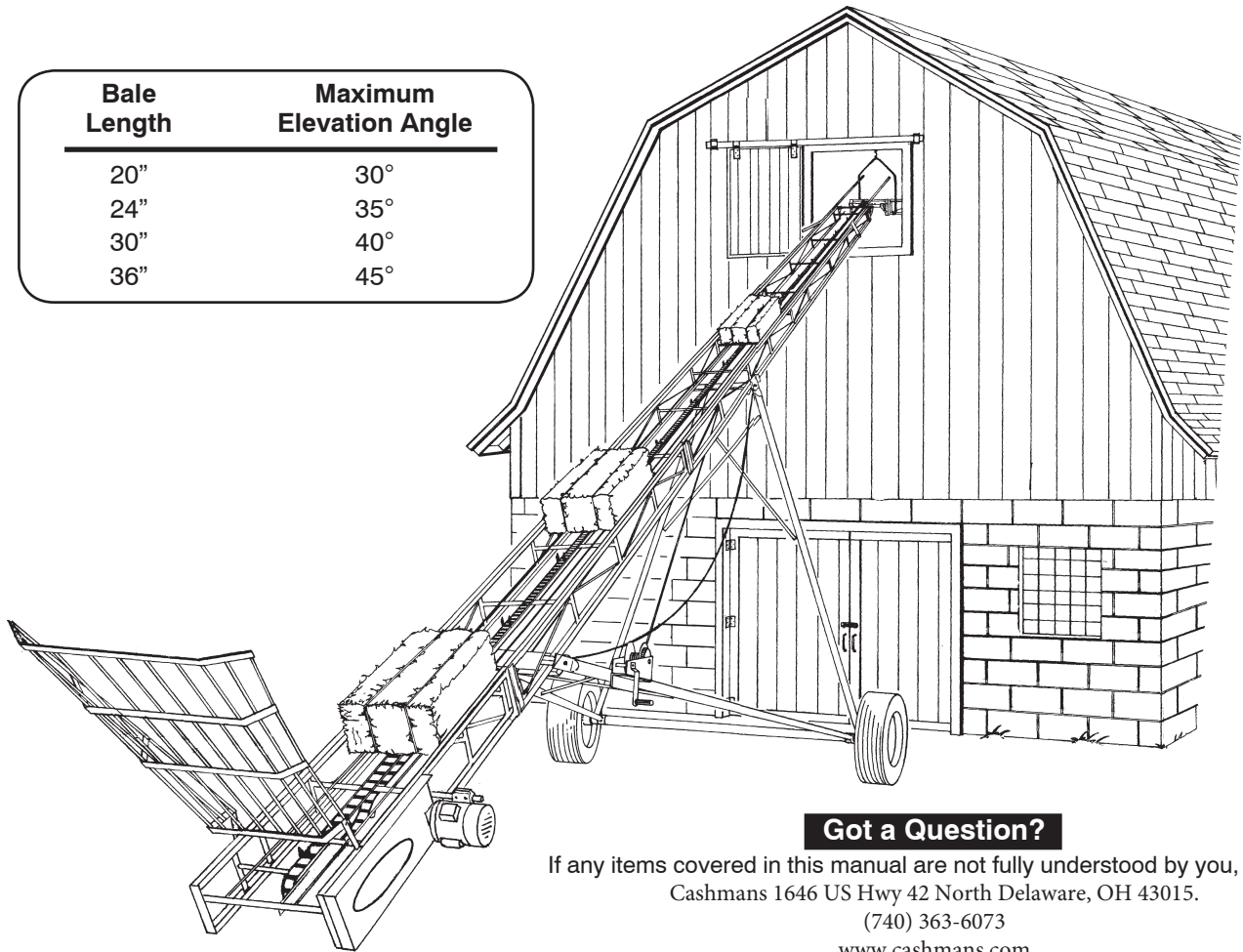

Got a Question?

If any items covered in this manual are not fully understood by you, contact
Cashmans 1646 US Hwy 42 North Delaware, OH 43015.

(740) 363-6073

www.cashmans.com

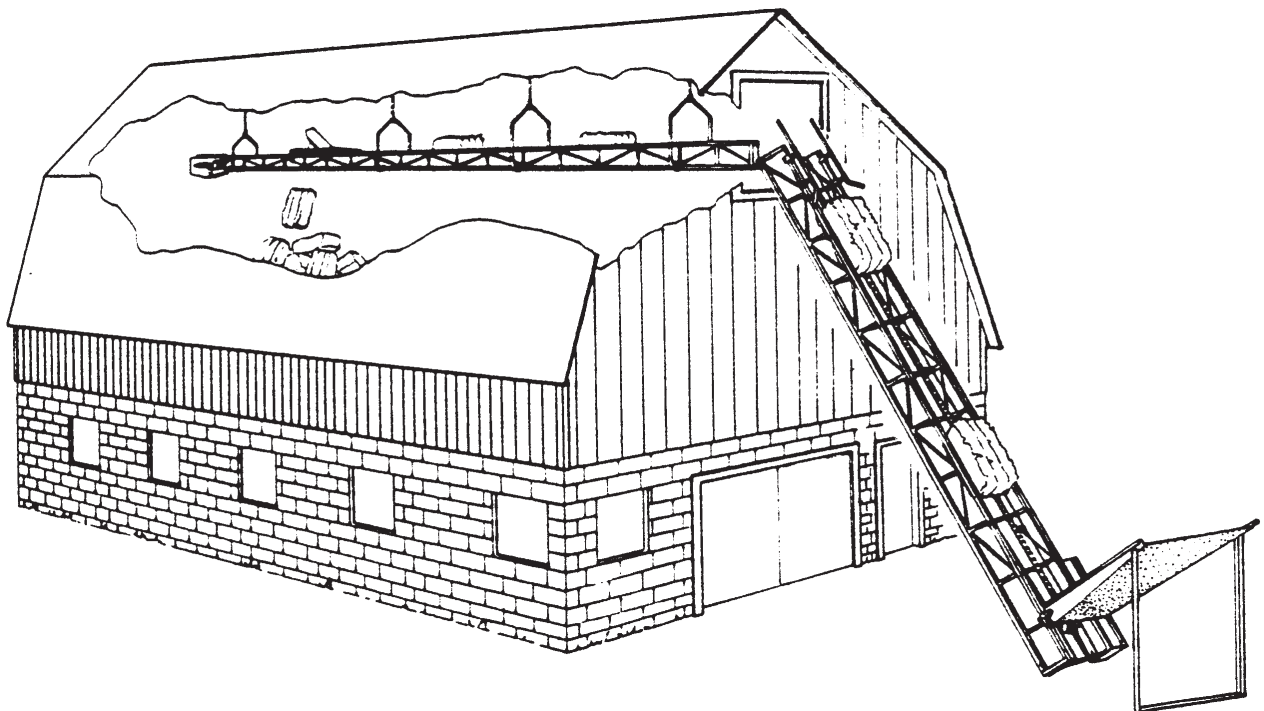

Machine Inspection

Inspect machine after delivery, upon completion of assembly and before each use. Machine inspection is mandatory.



Check that all guards are in place, secured, and functional. For information about guards, their location and free replacements, see page 44 of this manual.



Check all safety decals and replace any that are worn, missing, or illegible. For information about safety decals, their location, and free replacements, see page 3 or this manual.

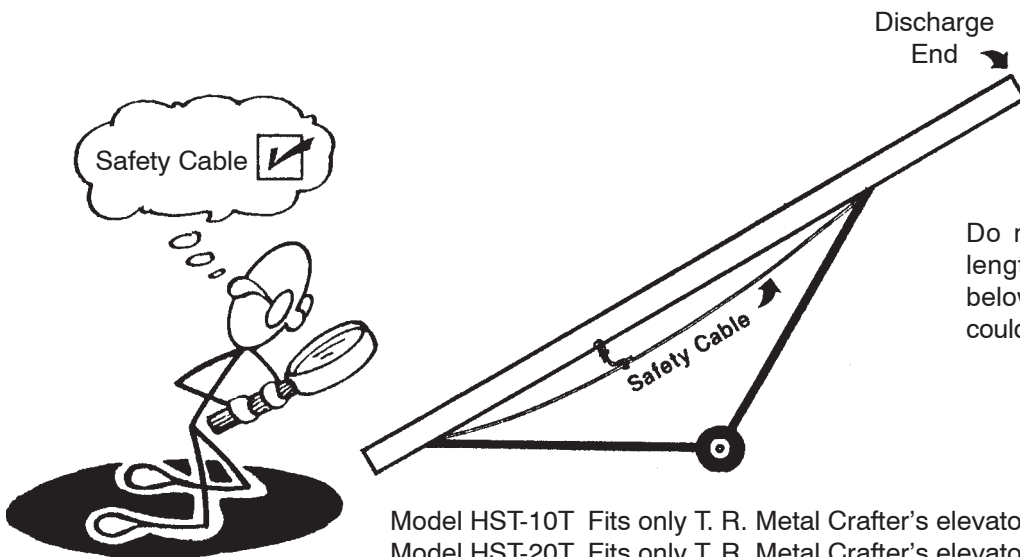

⚠ WARNING ⚠

Do not mount a longer or shorter length elevator than recommended below on transport. Failure to heed could result in personal injury or death.

Model HST-10T Fits only T. R. Metal Crafter's elevators
 Model HST-20T Fits only T. R. Metal Crafter's elevators
 Model HST-40T Fits only T. R. Metal Crafter's elevators

	HEC Standard Elevator Length	EHD Extra-Heavy-Duty Elevator Length
	20' - 32'	24' - 30'
	36'	36' - 48'
	N/A	54' - 60'

Make sure the safety cable is installed onto transport at the correct location. Refer to Transport Manual for instructions. The safety cable prevents transport from being lowered to an unsafe working position. Failure to install safety cable may result in personal injury or death. Note: Elevator weight should never rest on transport safety cable during normal operation. If safety cable is lost or missing, contact T. R. Metal Crafters, Inc. for free replacement.

Machine Inspection

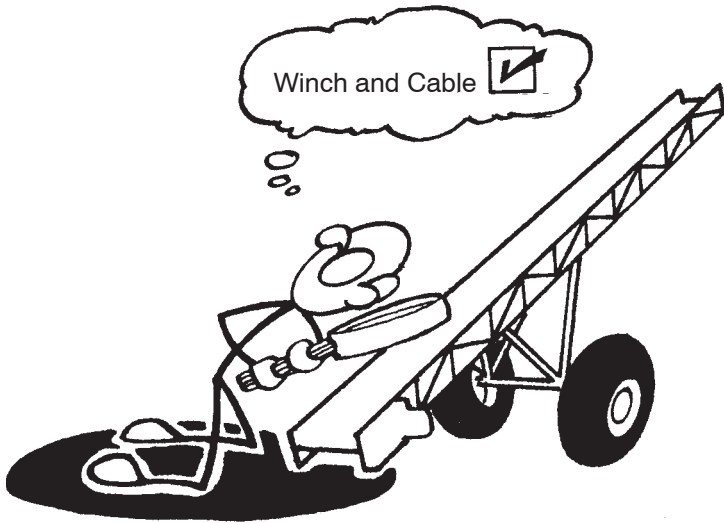

⚠ DANGER ⚠

Check winch and cable for condition, security, and operation. There should be at least 3-complete wraps of cable around winch drum in full down position. The cable anchor on the winch drum must be tight.

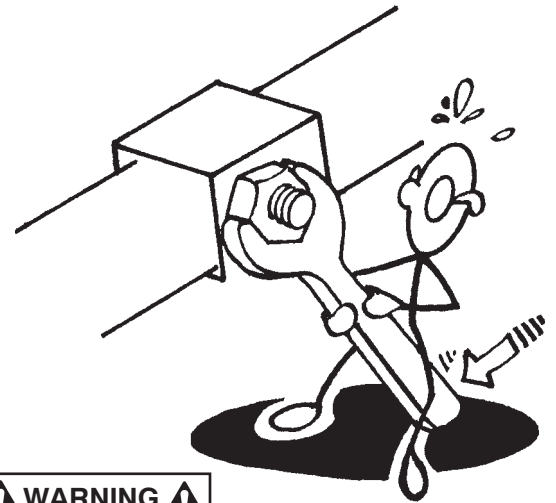

⚠ WARNING ⚠

1. Are all fasteners tight?
2. Are all belts and chains properly adjusted? (See Service and Maintenance Section of this manual).
3. Check all lubrication points. (See Service and Maintenance Section of this manual).

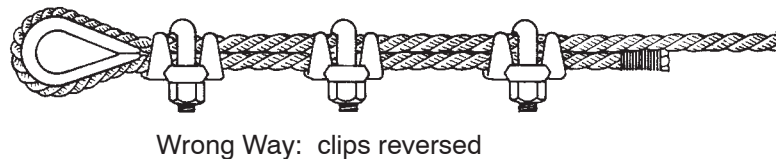
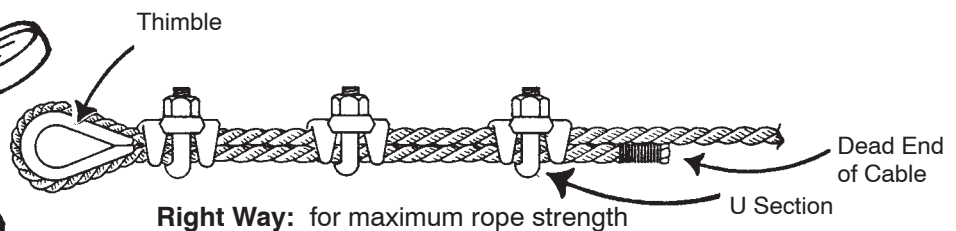
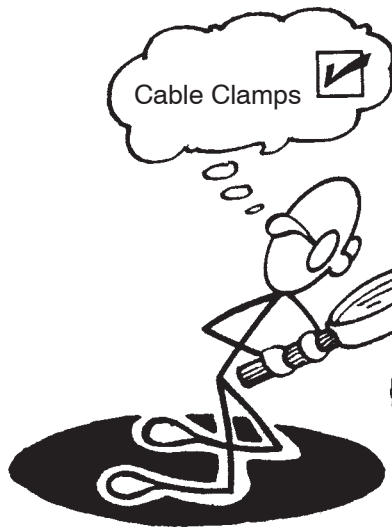

⚠ DANGER ⚠

The correct way to attach cable clamps is shown at the top; the “U” section is in contact with the rope’s dead end and is clear of the thimble.

Winch Operating Instructions



Read Carefully: Instructions for Safer Operation of your Winch

This winch is of general purpose design. The load rating is based on an intermittent duty cycle. High forces may be created by use of winch, creating potential safety hazards. Do not allow anyone who is not familiar with these operating instructions to operate the winch.



This winch is not designed to be a human hoist and should never be operated when there are persons positioned on or under the load being moved. The winch is designed for raising the elevator weight only! Do not lift other items with the elevator.

1. The winch must be securely bolted down to its mounting plate. The cable must be securely fastened to the transport and to the winch drum.
2. Never fully extend the cable. Always keep at least three (3) complete turns of cable around the drum. Otherwise cable can pull loose from the drum.
3. Always be sure the cable is pulling straight off the winch—not at an angle. This will prevent the cable from rubbing against the sides of the drum and becoming damaged.
4. Never stand along side the winch cable or guide the cable with your hands. Always inspect the cable and cable clamps for damage before each use. Replace the cable if it is frayed or kinked. If the cable breaks, it can act like a whip and inflict serious injury to anyone in the path of the cable.
5. Never permit anyone to stand on or under the elevator when it is being raised, lowered or pulled. This machine is not grounded. Keep **at least** 10 feet away from overhead electrical wires and obstructions. Electrocution can occur **without direct contact**.
6. Elevator should be in the down position or secured to building when unattended as unauthorized persons may attempt to operate the winch, thereby creating an unsafe condition.
7. Never lower transport to **straight-out** position — transport legs may bend due to increased stress.
8. Always keep the winch lubricated per instructions. Remember, worn-out parts cause unsafe conditions.

This winch is equipped with a brake that is actuated by turning the handle. The brake is designed to hold the load whenever the handle is released.

1. Never operate winch with wet or oily hands and always use a firm grip on the handle.
2. To raise the elevator, turn the handle clockwise and listen for the “loud clicking sound” of the ratchet. If the clicking sound stops, keep a firm grip on the handle and return the elevator to the down position by turning the handle counterclockwise. Repair the winch.
3. To lower the elevator, turn the handle counterclockwise (no clicking sound)—the ratchet pawls should be fully engaged into the ratchet gear teeth. To stop while lowering the load, turn the handle clockwise until you hear two clicks (about 6 inch movement of the handle). **Note:** If your hand slips off of the handle while turning it counterclockwise, the brake will prevent the handle from spinning backwards. **The brake is not fully locked until the handle is turned clockwise far enough to hear two clicks.**
4. To pull the cable off the winch without a load, you must pull on the cable and turn the handle counterclockwise at the same time. The Load-Lok brake is always actuated so the winch can not freewheel.
5. Always inspect the brake disc for wear prior to each use. If less than 1/16” thick, cracked or broken, it should be replaced. The brake disc will get hot when lowering the load. If brake is smoking or squeals, stop lowering and let the brake cool for 15 minutes. **Do not touch brake.**

Movement and Placement

Right

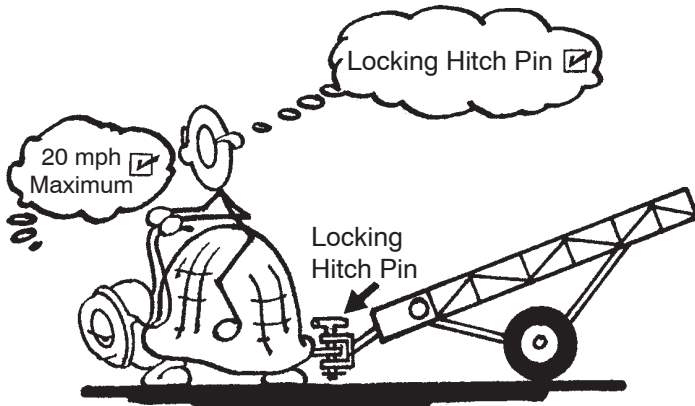

Wrong

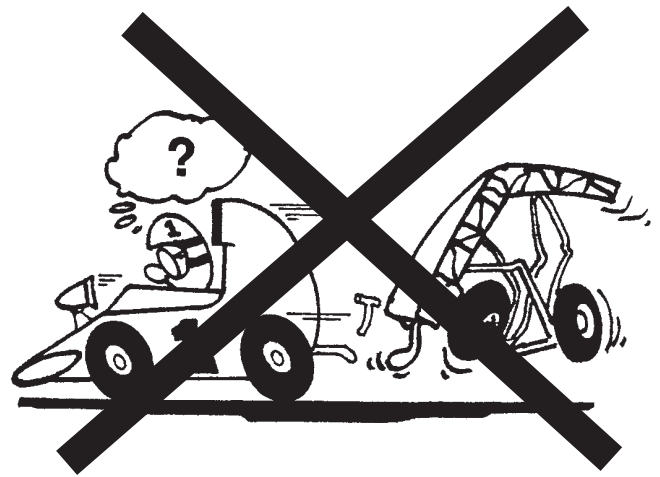

1. Elevator must be empty and in down position (with light tension on safety cable), before moving.
2. Use a locking hitch pin.
3. Transports are designed **only** for towing at tractor speeds up to 20 mph between sunrise and sunset. Check and comply with all state and local regulations governing marking, lighting, towing and maximum width.

Right

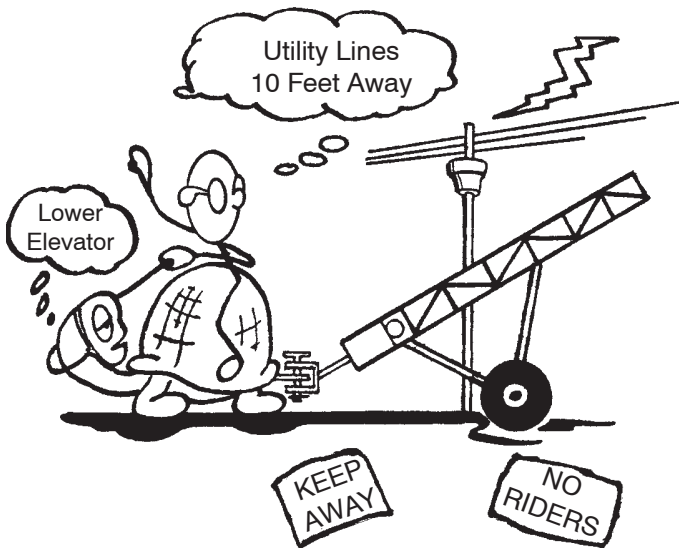

Wrong

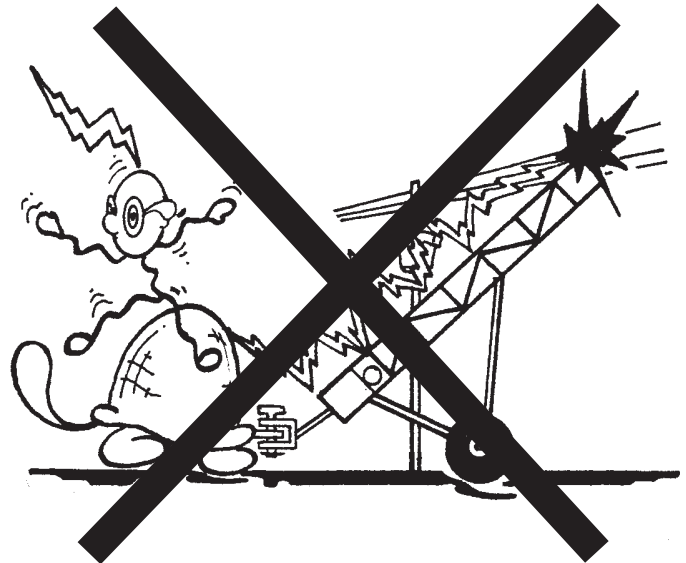

1. This machine is not insulated. When moving, upper end can contact electric utility lines and overhead obstructions.
2. Lower elevator well below level of power lines before moving.
3. Keep at least 10 feet away from overhead electrical wires and devices. Electrocution can occur without direct contact.

Movement and Placement

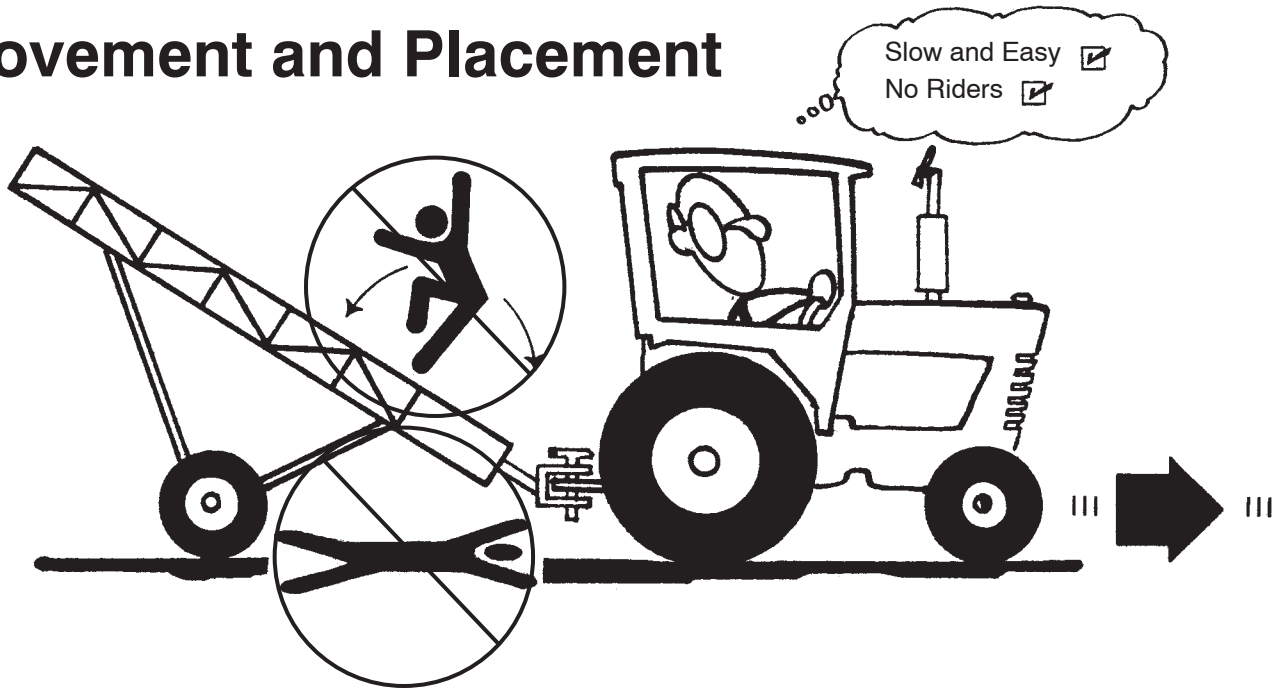

1. Do not allow anyone to ride on or stand below elevator and/or transport at any time.
2. Care should be exercised when traveling on rough and uneven terrain to avoid upsetting.
3. Leave elevator in recommended down position until final positioning requires raising it.

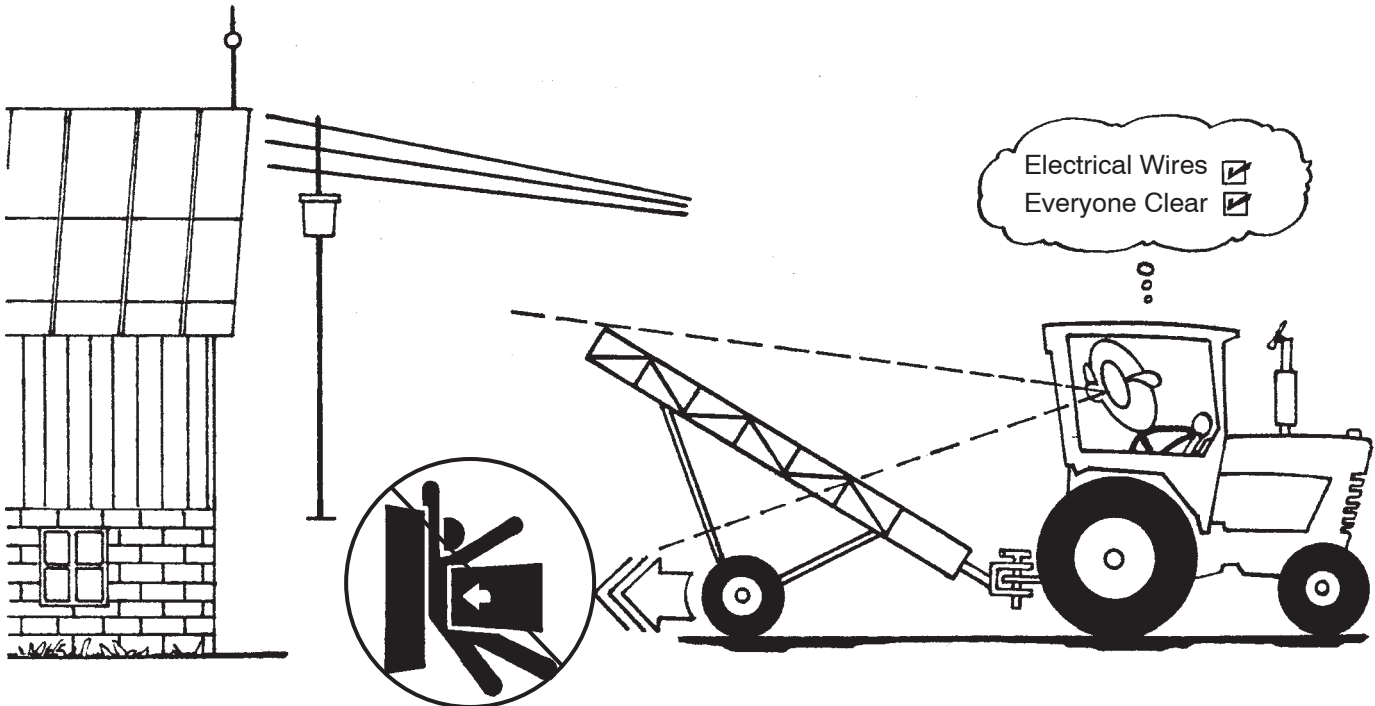

1. Never move the elevator manually. Use a vehicle. When releasing from or attaching to the vehicle, test the hitch end for downward weight. Lift it slowly and keep the hitch end no higher than the tractor tow bar. Be sure elevator is empty before lifting or moving.
2. During placement, make sure entire area above elevator and in line of travel is clear of obstructions and electrical wires. Failure to stay clear of electrical wires will result in electrocution.
3. Move elevator slowly into working position with towing vehicle, not by hand. Make certain everyone is clear of the work area.

Movement and Placement

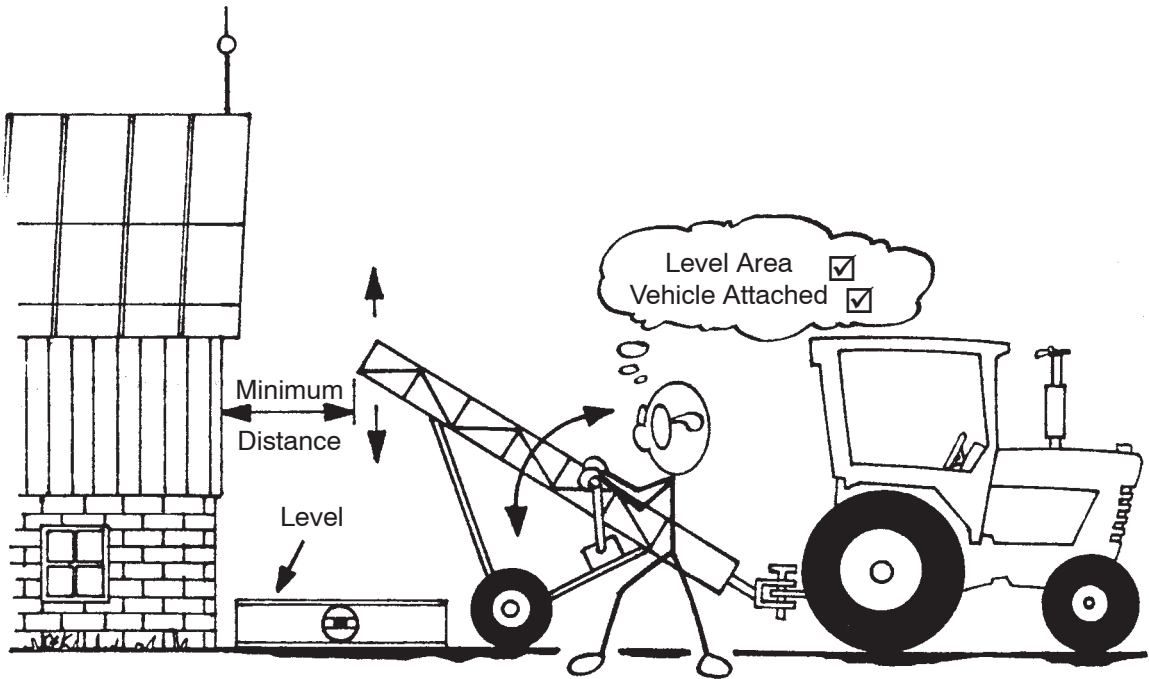

Keep distance between elevator and barn to a minimum when positioning a raised elevator. The elevator must be on a level surface, attached to a vehicle, and the wheels must be free to move when raising or lowering.

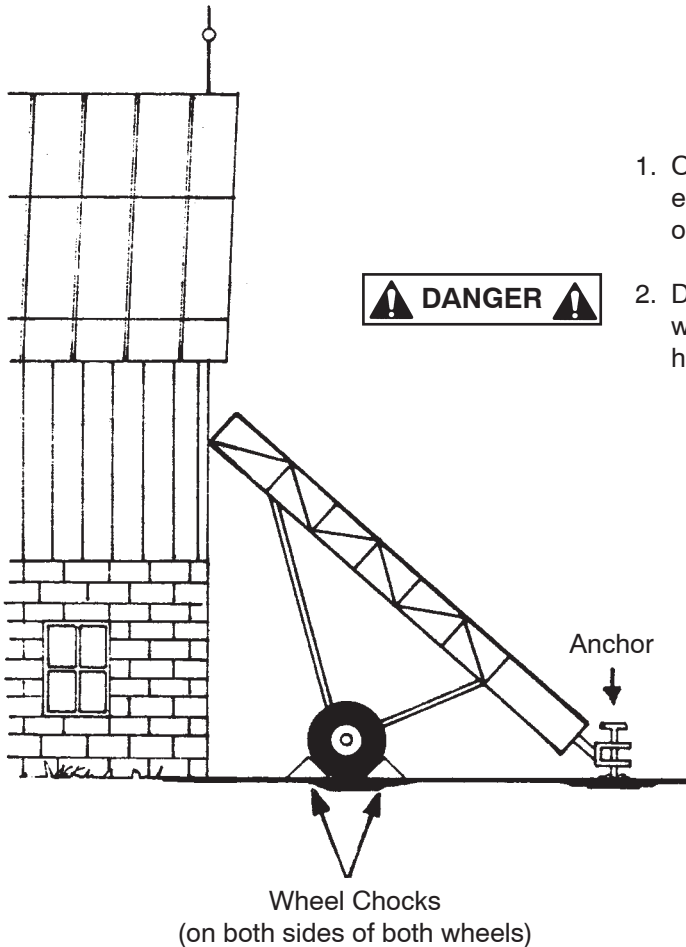

1. Once in place, the elevator should be anchored at the hitch end and/or supported at the discharge end. The wheels on the elevator should be chocked on both sides.
2. Do not attempt to increase elevator height by positioning wheels on lumber, blocks, or by other means. Failure to heed may result in personal injury or death.

Electric Motor Drive



1. Electric motors and controls shall be installed by a certified electrician and must meet the standards set by the National Electrical Code and all local and state codes.

2. A magnetic starter should be used to protect your motor.



3. Electric motor must be totally enclosed, fan cooled and have a manual reset overload protector. Use a motor that is rated between 1725 to 1800 RPM.

4. Be sure that the wiring to the electric motor is large enough and the power source is the right voltage and frequency for the motor used. Make certain that all electrical assemblies are grounded and located in a weatherproof dry location.



5. Do not operate equipment without all shielding in place.

6. Keep electric motors and motor fans clean of hay and dust. This will allow motor to cool properly.



7. Be certain to keep all wiring and controls out of reach of livestock and children.

8. Check and determine that the belts are in line.

9. Make certain that the belts are snugged up but not overtightened. Overtightened belts will cause pulley and bearing failure. If belt tension is correct, belt can be depressed about 1/2" to 3/4" at midpoint between pulleys. Replace pulleys when pulley grooves are worn enough to cause belt slippage.



10. You must disconnect and lockout power source before resetting your motor (see lockout/tagout rules on following page).

11. Reset and motor starting controls must be located so that the operator has full view of the entire operation.

12. Use a 2.8" O.D. Type A, cast iron motor pulley (not included).

13. Make certain that the motor horsepower is adequate and is properly matched to the motor pulley.



14. Do not use an electric motor of lower horsepower than specified in our "Horsepower Requirements Guide". Failure to heed these instructions can result in personal *injury or death!*

New Lockout/Tagout Rule Becomes Effective



New Occupational Safety and Health Administration (OSHA) regulations on locking out or tagging out equipment prior to maintenance became effective October 31, 1989. The new rule requires that any equipment subject to restarting be locked out — when possible — prior to servicing. When lockout is not possible, equipment must be tagged.

Previous lockout/tagout regulations allowed a choice between locking and tagging. But the new rule permits sole use of warning tags only if the employer can prove that equipment cannot be locked out or that tagging is adequate protection.

Employers are also required to thoroughly document exactly how workers are to turn off equipment, disconnect it, and verify that it has been de-energized. Workers, including contractors, must be notified of the lockout/tagout procedures.

Main Power Disconnect Switch

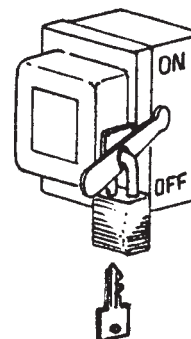

Lockout: A main power disconnect switch capable of being locked only in the OFF position shall be provided. This shall be locked whenever work is being done on the equipment.

Safety Lockouts Illustrated

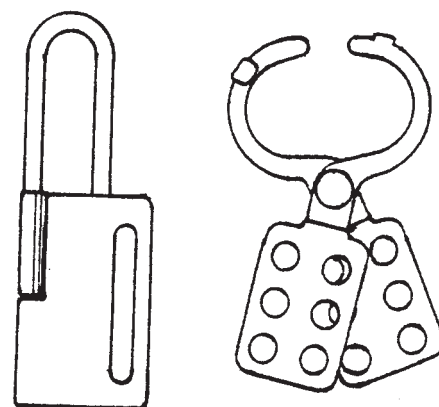

Horsepower Requirements

Bales should be “pulled toward” electric-motor drive end. However, if elevator is mounted on a transport, drive end must remain on ground and “push bales”.

Horizontal Conveyor



1/2 HP	16' – 28'
3/4 HP	30' – 44'
1 HP	48' – 60'
1-1/2 HP	64' – 90'
2 HP	96' – 120'

Incline Elevator

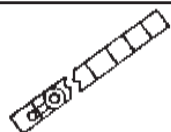

1/2 HP	16' – 24'
3/4 HP	28' – 40'
1 HP	42' – 44'
1-1/2 HP	48' – 60'

Use 2.8" O.D. Type A motor pulley on horizontal conveyor and incline elevator. Use a motor that is rated between 1725 to 1800 RPM.

NOTE: The above chart is only a guide — the size, shape and weight of your bales; angle of elevator; and desired speed may affect your installation. Remember, bales are more effectively pulled than pushed. Less horsepower is required when pulled!

Safety Lockouts In Use On Switch Boxes

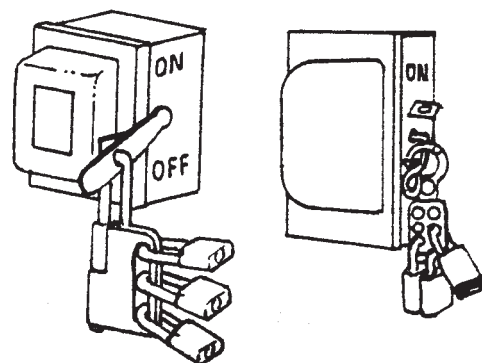

Attaches to main power disconnect switch. Equipment cannot be started until all workmen have removed their personal padlocks.

14 **Work Area Diagram – Unloading Baled Hay**



1. The work area shown below should be marked off with barriers.
2. It shall be the duty of the operator to see that children and/or other persons stay out of the work area! Trespass into the work area by anyone not involved in the actual operation, or trespass into a hazard area by anyone, shall result in an immediate shut down by the operator.
3. Prior to start up and during operation, it shall be the responsibility of the operator to see that the work area has secure footing, is clean and free of all debris and tools which might cause accidental tripping and/or falling.



Under elevator and under transport area
Keep Out!



Work Area
Authorized Personnel Only



Falling
Hay
Bales



Elevator Motor Drive Area
Hazard — Keep Out!

Wheel Chocks

Wheel Chocks

Chock All Wheels

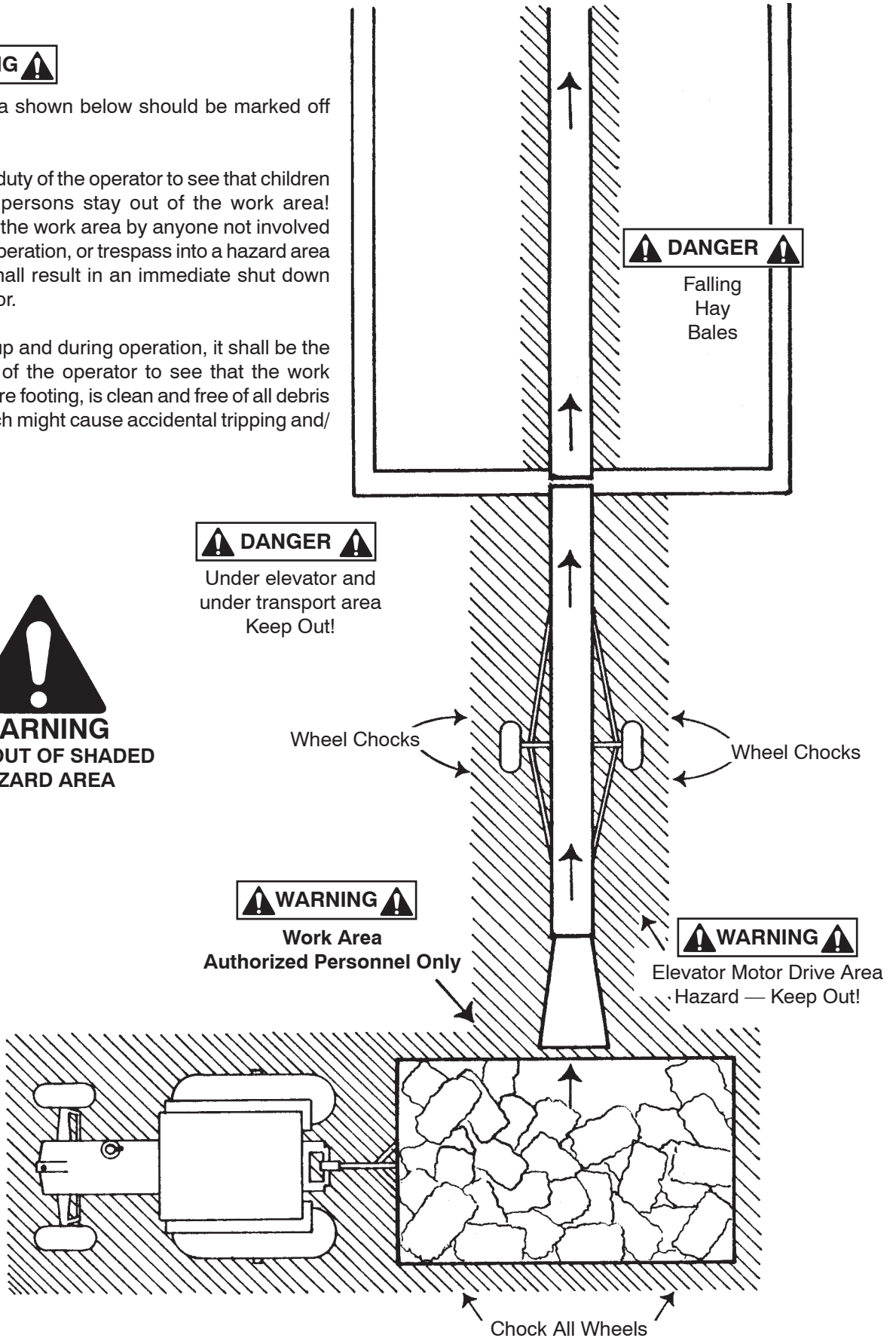

Work Area Diagram – Movement and Placement

⚠ DANGER ⚠

Under elevator and under transport area
KEEP OUT!

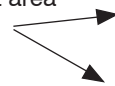

⚠ DANGER ⚠

**OVERHEAD WIRES
KEEP AWAY!**

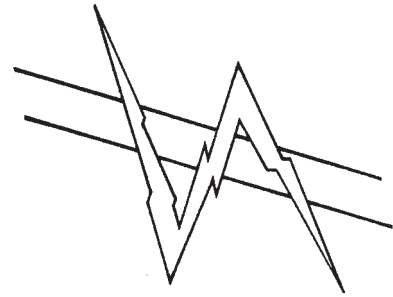

⚠ WARNING ⚠

**HAZARD AREA
KEEP OUT!**

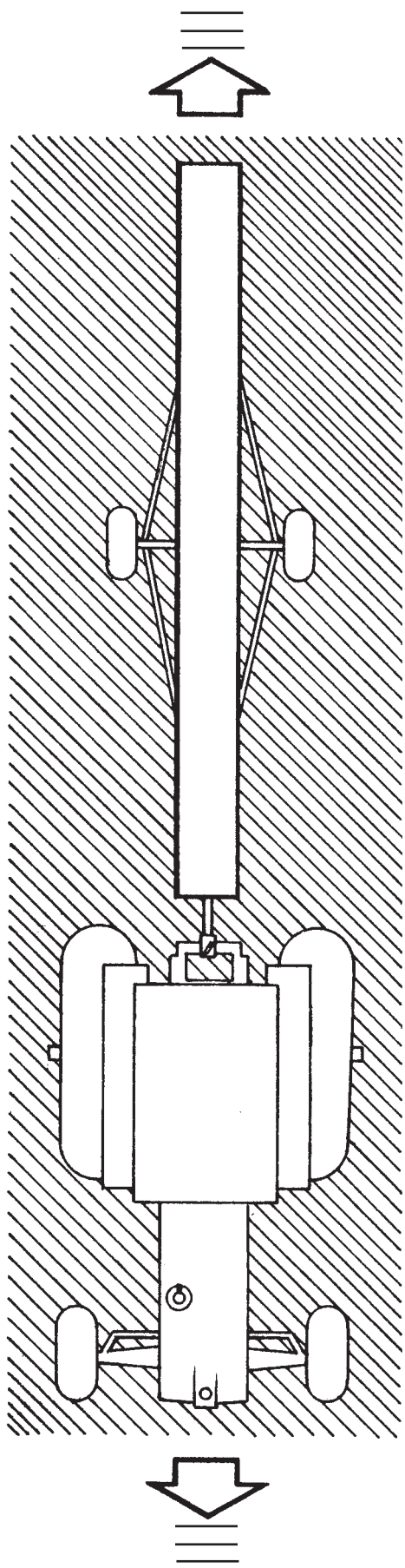

**KEEP OUT OF SHADED
HAZARD AREA**

Elevator Operation



Do not allow persons to stand below or ride bales up elevator at any time.

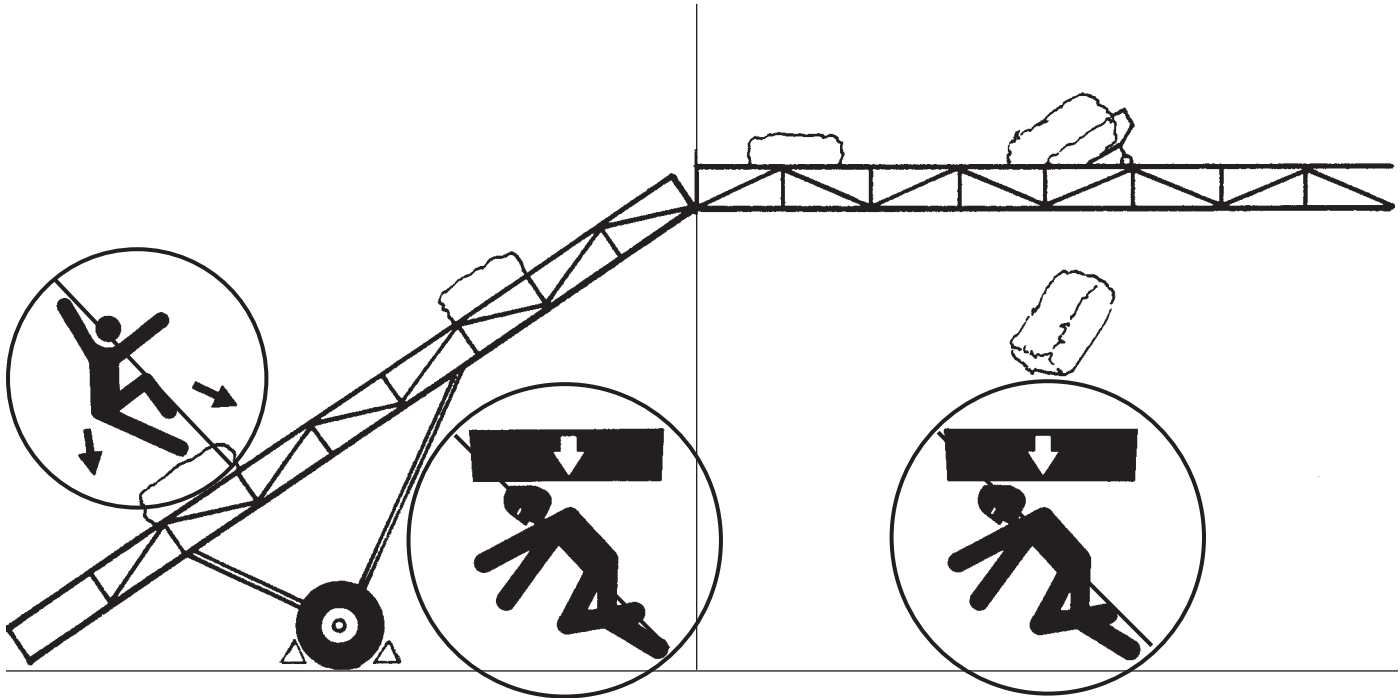

1. Observe work area restrictions.
2. Keep all safety shields and devices in place.
3. Make certain everyone is clear before operating or moving the machine.
4. Keep hands, feet, hair, and clothing away from moving parts.
5. Shut OFF power and lock out to adjust, service, or clean.

Important Break-in Instructions

Check and make sure that bearings on drive unit and tightener end contain grease. Pour a light stream of heavy oil onto elevator chain before running elevator. Oil will reduce friction, quiet elevator and greatly extend chain life. Run empty elevator for thirty minutes after final assembly. Because bolts do have a tendency to loosen and chains tend to flex after initial use, this will give you time to make the break-in adjustments and check that elevator functions properly before you start making hay. Check and tighten any loose bolts. Elevator chain will loosen after use and should be readjusted in the following order:

1. Loosen chain tightener and remove extra links from conveyor chain.
2. Connect and retighten conveyor chain until snug.

Important — first remove extra chain links before using chain tightener. Failure to remove extra chain links will result in chain tightener not being able to take up all of the slack chain.

***THIS PAGE LEFT
INTENTIONALLY
BLANK***

Bale Kick-off Operation and Assembly

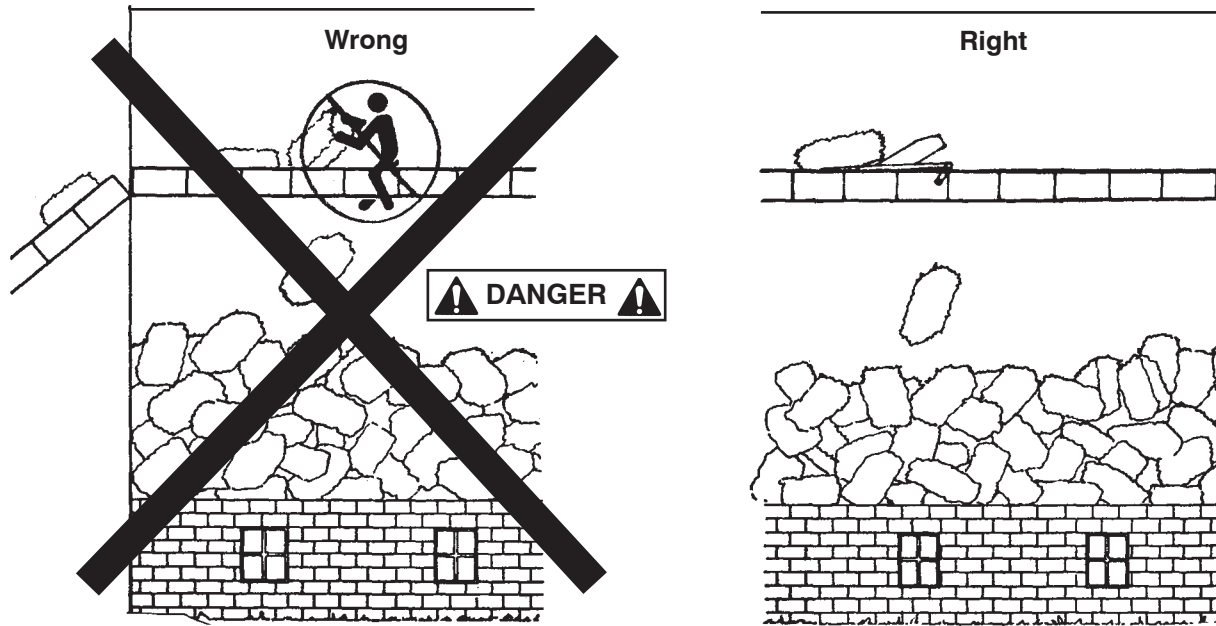

Do not knock bales off conveyor by hand. Use an Automatic Bale Kick-off available from the factory. Failure to heed these instructions will result in personal injury or death!

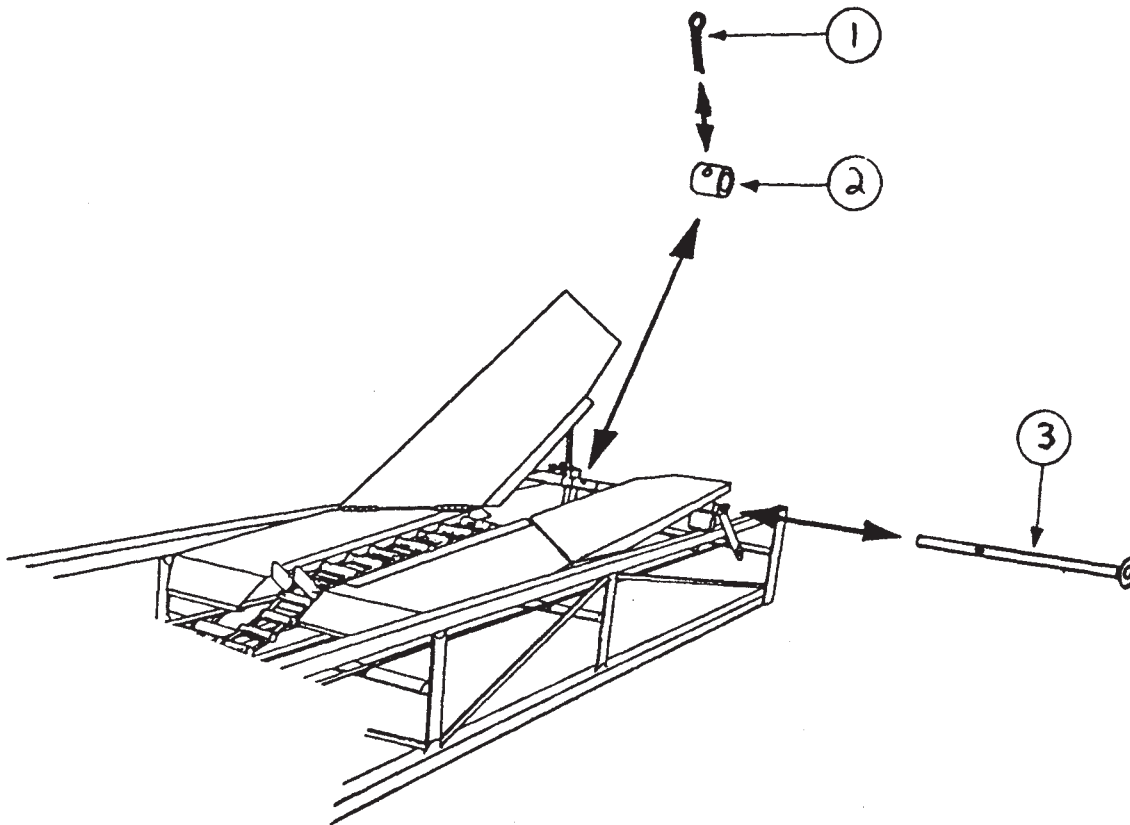

Tapered design provides for unloading to either right or left along conveyor. Kick-off may be removed from or installed onto conveyor without breaking the conveyor chain. Remove cotter pin #1 and pull out kick-off axle #3 and spacer #2. Lift conveyor chain up from conveyor chain track. Conveyor chain should ride over green plastic wear strip and under kick-off axle. Reassemble kick-off axle, spacer and cotter pin.

Bale Kick-off Operation and Assembly

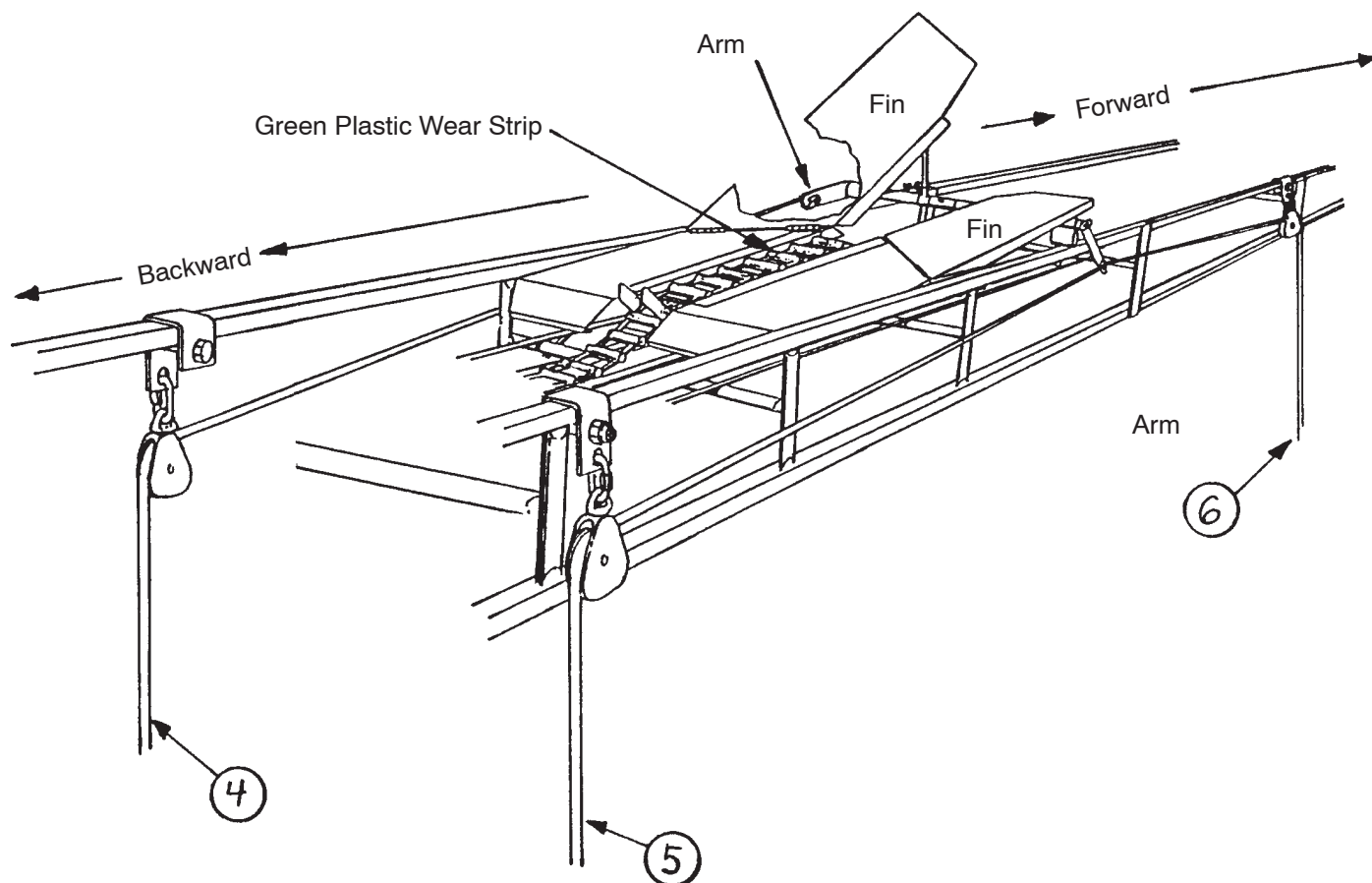

Each kick-off requires 3 control ropes. Use a 1/4" low-stretch grade, nylon rope. The length of each control rope is equal to the conveyor length plus distance of conveyor to barn floor. Install control ropes as shown in the following illustrations.

Pull control rope #4 or #5 to change direction of unloading (right or left side of conveyor), or to slide kick-off backward along conveyor. Pull control rope #6 to slide kick-off forward along conveyor. Pulling one arm backward and raising the fin above it will automatically push the opposite arm forward, lowering the fin above it.

To secure the kick-off during operation, tie the end of the control rope #4 or #5 to a sturdy anchor point. Use the control rope #4 or #5 that is connected to the kick-off arm in the backward position. The side of the kick-off with the arm in the backward position is also the side of the kick-off with the fin in the up position. Securing the backward arm holds the fin in the up position and prevents a hay bale from pushing the kick-off along toward the end of the conveyor.

Bales should not be run over the top of the kick-off and back down into the conveyor. The kick-off lifts the conveyor chain out of the conveyor chain track. When the bale travels over the top of the kick-off and back down into the conveyor, it may push the chain off to the side of the conveyor chain track. The weight of the bale will hold the chain to the side of the conveyor chain track, and as it reaches the end of the conveyor, it may be derailed from the drive sprocket.

Elevator Shutdown

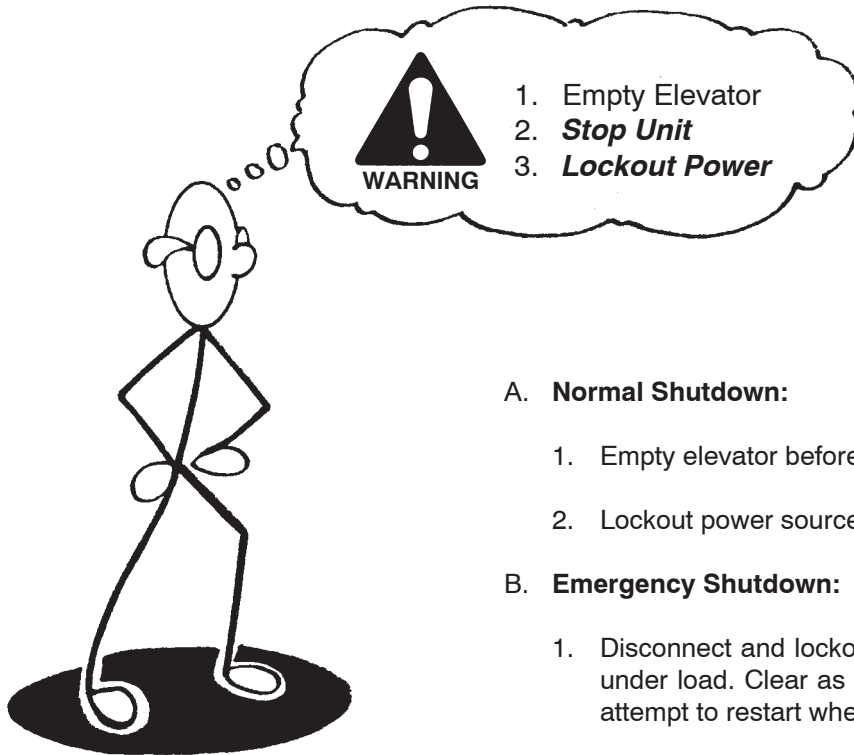

A. Normal Shutdown:

1. Empty elevator before stopping unit.
2. Lockout power source before operator leaves work area.

B. Emergency Shutdown: WARNING

1. Disconnect and lockout the power source if elevator shuts down under load. Clear as much hay from elevator as you can. Never attempt to restart when full.
2. Starting the unit under load may result in damage to the elevator. Such damage is considered abuse of the equipment.

Cleanup and Storage



When the operation has been completed:

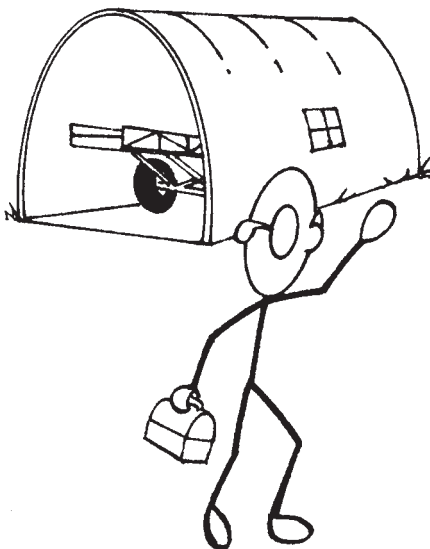

1. Clean entire work area.
2. Remove anchors, supports, and chocks.
3. Move elevator slowly out of “working” position with towing vehicle - not by hand.
4. If not in “transport” position, lower elevator to the “full down” position immediately upon clearance of any obstructions.
5. Transport to the new work area or storage area. Observe previous movement and placement instructions. Store elevator in the “full down” position with hitch end anchored.

Optional Accessories

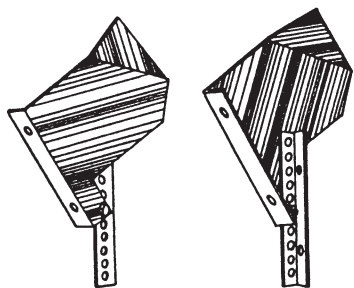

Connector plates: Connects incline elevator to horizontal mower conveyor. Prevents bales from turning and tumbling out when transferring.

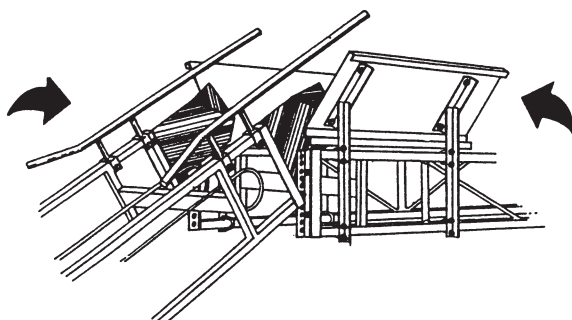

Above drawing illustrates incline elevator assembled to horizontal conveyor, using Bale Guides (model HST-7A), Connector Plates (model HST-17A or 18A) and Bale Arrangers (model HST-16A).

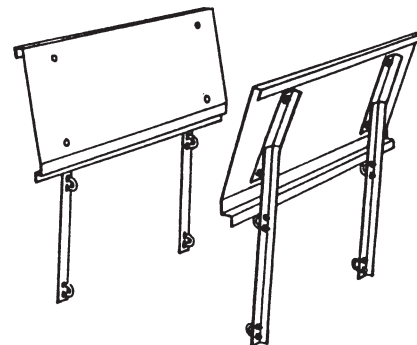

Bale arrangers: Directs irregular shaped bales into horizontal conveyor. Made of heavy galvanized steel.

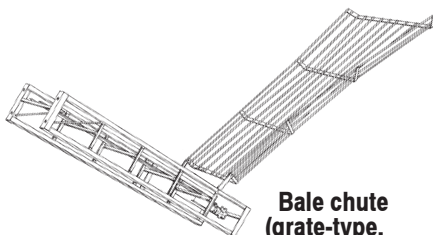

**Bale chute
(grate-type,
6' length)**

Hinges to elevator — tips back against wagon or truck for easy unloading. Long-taper design automatically lines up each bale to prevent them from tipping or turning while being conveyed up elevator. Grate-type construction permits loose material to fall through for smoother operation.

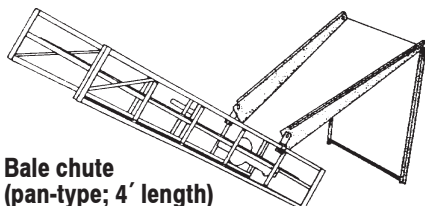

**Bale chute
(pan-type; 4' length)**

Hinges to elevator — rests on its own stand or tips back against wagon or truck for easy unloading. Made of heavy, galvanized steel. Short-taper design automatically lines up each bale to prevent them from tipping or turning while being conveyed up elevator.

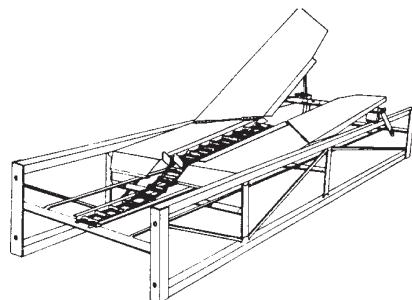

Bale kickoff Sturdy, tapered design provides for fast, smooth, accurate unloading to either right or left from any point along conveyor. Pull control rope (rope not included), from mow floor to change direction of unloading or to slide kickoff to any position along full length of conveyor. Bales cannot be conveyed over kickoff and onward toward end of conveyor.

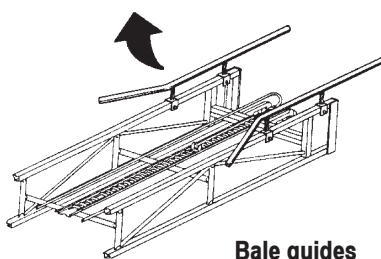

Bale guides

Keeps bale twine from catching and breaking when bales are discharging from a steeply inclined elevator. Prevents bales from tipping and turning and then tumbling out when transferring from an inclined elevator to mower conveyor. Pair of sturdy steel tubes clamp onto sides of inclined elevator on top end.

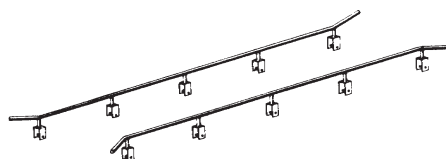

Bale rails

Rails increase height of elevator sides to prevent irregular-shaped bales from tumbling out. Rigid 12' long steel rails clamp onto sides of inclined elevator.

Mow hangers

Makes it simple and easy to install conveyor from hay track, rafters, or roof. Sturdy tubular steel hangers are extra wide to prevent bales from snagging. Recommended at ends and every 12' of conveyor length for proper support.

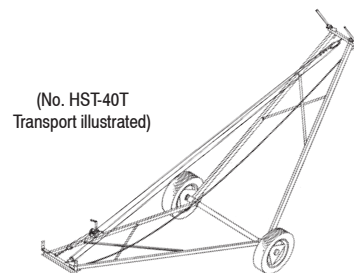
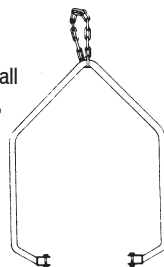

(No. HST-40T
Transport illustrated)

Transports Engineered for better balance and greater strength — now you can move your elevator with ease to exactly where you want it. Rugged, oversize 2" x 3" x 1/8" steel tubing transports are extra heavy for more strength. Wheels are set far apart for increased stability. Equipped with 15" four-bolt, ag-type wheel rims (less rubber tires) mounted on regreaseable, tapered roller bearings (max. speed — 20 mph). Transport can be quickly raised from towing position up to 45°. Sturdy, easy-to-operate hand winch features double-disc, automatic brake system for positive load control. Winch is zinc plated to resist rust.

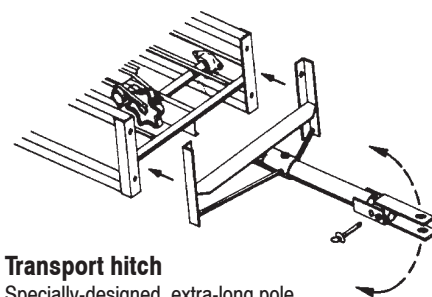

Transport hitch

Specially-designed, extra-long pole to prevent elevator from binding against tractor or truck bumper during short turns — pole unpins for easy removal. Pin can be removed from rigid clevis to permit swiveling — prevents tractor or truck hitch pin from binding when elevator is raised.

Trouble Shooting Guide

Symptom: Bales fall off elevator before reaching mow conveyor.

Problem: Bales are not loaded onto elevator properly.

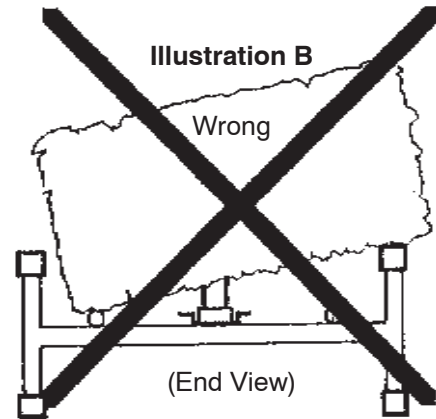
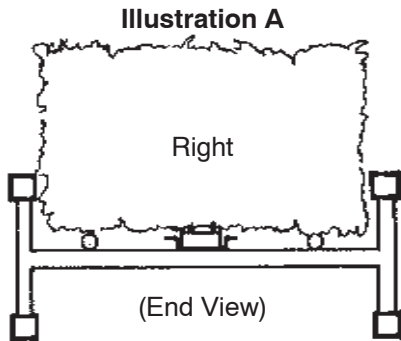

SOLUTION: Load bales as shown in Illustration A above or use a Bale Chute accessory (*Model No. HST-5A or HST-12A*), as shown below.

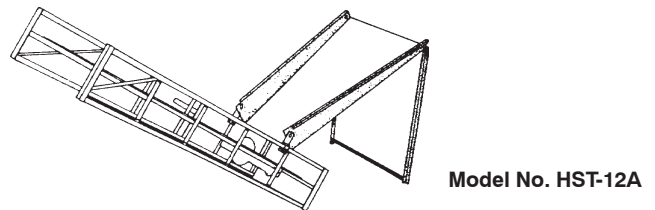
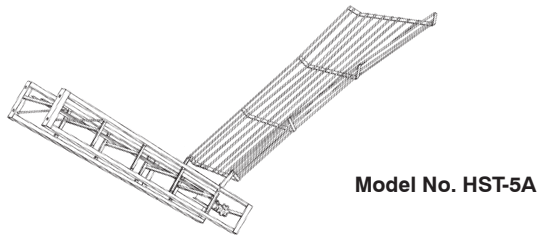

Bale chute (grate-type, 6' length): Hinges to elevator — tips back against wagon or truck for easy unloading. Long-taper design automatically lines up each bale to prevent them from tipping or turning while being conveyed up elevator. Grate-type construction permits loose material to fall through for smoother operation.

Bale chute (pan-type; 4' length): Hinges to elevator — rests on its own stand or tips back against wagon or truck for easy unloading. Made of heavy, galvanized steel. Short-taper design automatically lines up each bale to prevent them from tipping or turning while being conveyed up elevator.

SOLUTION: Use Bale Side Rail accessory (*HST-6A*)

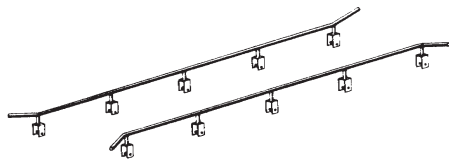

Bale rails: Rails increase height of elevator sides to prevent irregular-shaped bales from tumbling out. Rigid 12' long steel rails clamp onto sides of inclined elevator.

Problem: Hay possibly not being properly baled.

SOLUTION: Operate baler within speed range recommended by manufacturer to obtain properly baled hay.

Problem: Bale string knots are breaking.

SOLUTION: Repair knot tying mechanism in baler.

Problem: Elevator positioned at too steep of an angle.

SOLUTION: Decrease elevator angle.

Problem: Elevator speed is too fast.

SOLUTION: Use a 2.8" O.D. motor pulley.

Trouble Shooting Guide

Symptom: Conveyor chain breaks apart during operation.

Problem: Loose conveyor chain catching on elevator.

SOLUTION: Tighten chain. Important — first remove extra chain links before using chain tightener. Failure to remove extra chain links will result in chain tightener not being able to take up all of the slack chain.

Problem: Conveyor chain is worn out.

SOLUTION: Replace worn chain.

Problem: Chain return guides are worn out or defective.

SOLUTION: Replace chain return guides.

Problem: Elevator sprocket may have a bad tooth.

SOLUTION: Replace worn sprockets.

Symptom: Conveyor chain become loose when conveyor is loaded, but snug when conveyor is empty.

Problem: Elevator chain is not tightened properly.

SOLUTION: Tighten chain. Important — first remove extra chain links before using chain tightener. Failure to remove extra chain links will result in chain tightener not being able to take up all of the slack chain.

Problem: Elevator too heavily loaded.

SOLUTION: Increase space between bales when loading elevator.

Problem: Elevator positioned at steep angle.

SOLUTION: Decrease elevator angle.

Problem: Bales are being “pushed away” rather than “pulled toward” electric motor drive end. This may result in top “pushing” chain becoming slack and bottom “pulling” chain remaining snug.

SOLUTION: Reassemble elevator to pull bales toward electric motor drive end. Drive end must remain on ground and push bales if elevator is mounted on a transport.

Trouble Shooting Guide

Symptom: Elevator or conveyor tears hay loose from bottom side of bale.

Problem: Elevator or conveyor tracks do not line up properly.

SOLUTION: Gently hammer tracks into alignment. Properly aligned tracks will not grab hay from bottom of moving bales.

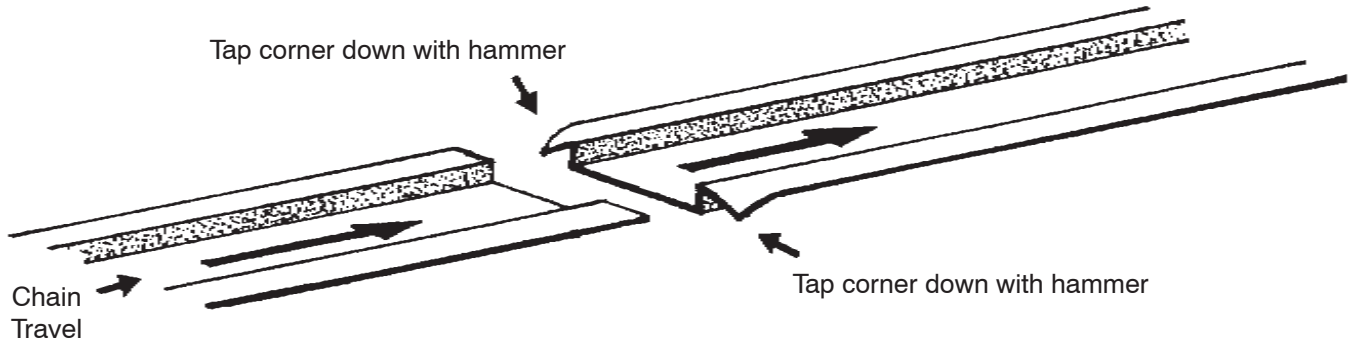

Symptom: Bales travel over kick-off and down conveyor.

Problem: Kick-off fin does not stay in up position.

SOLUTION: Secure kick-off with control rope (refer to illustration on page 18). When securing the kick-off, use the control rope that is connected to the kick-off arm in the backward position. The side of the kick-off with the arm in the backward position is also the side of the kick-off with the fin in the up position. Securing the backward arm holds the fin in the up position and prevents a hay bale from pushing the kick-off along toward the end of the conveyor.

Bales should not be run over the top of the kick-off and back down into the conveyor. The kick-off lifts the conveyor chain out of the conveyor chain track. When the bale travels over the top of the kick-off and back down into the conveyor, it may push the chain off to the side of the conveyor chain track. The weight of the bale will hold the chain off to the side of the conveyor chain track, and as it reaches the end of the conveyor, it may be derailed from the drive sprocket.

Symptom: Bales are bunching up at the kick-off and not going over the side smoothly.

Problem: Kick-off model does not match Conveyor model.

SOLUTION: Contact the factory for assistance in model identification.

Symptom: Bales travel up kick-off and wedge against the ceiling.

Problem: Conveyor possibly hung too close toward ceiling.

SOLUTION: Lower the conveyor to increase ceiling clearance.

Trouble Shooting Guide

Symptom:

Bales are bunching up at kick-off and not going over the side smoothly.

Problem:

Mow Conveyor is not setting level.

Problem:

Motor weight at drive end pulls one side of the conveyor down.

Problem:

Mow Hangers are not installed level.

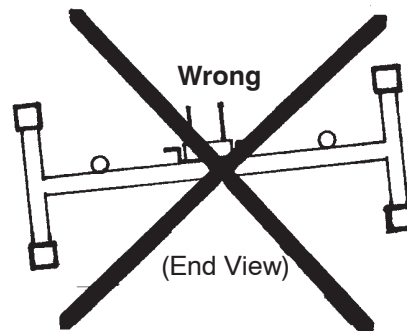
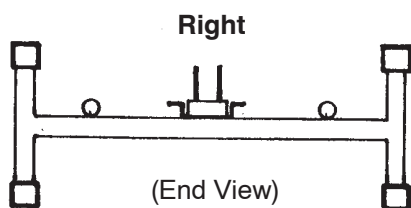
SOLUTION:

Clamp conveyor to a solid wood mow-hanger as shown below. Locate wood mow-hanger near motor drive end of conveyor, as weight imbalance (due to motor) is greatest at that point. Wood mow-hangers are not available from the factory.

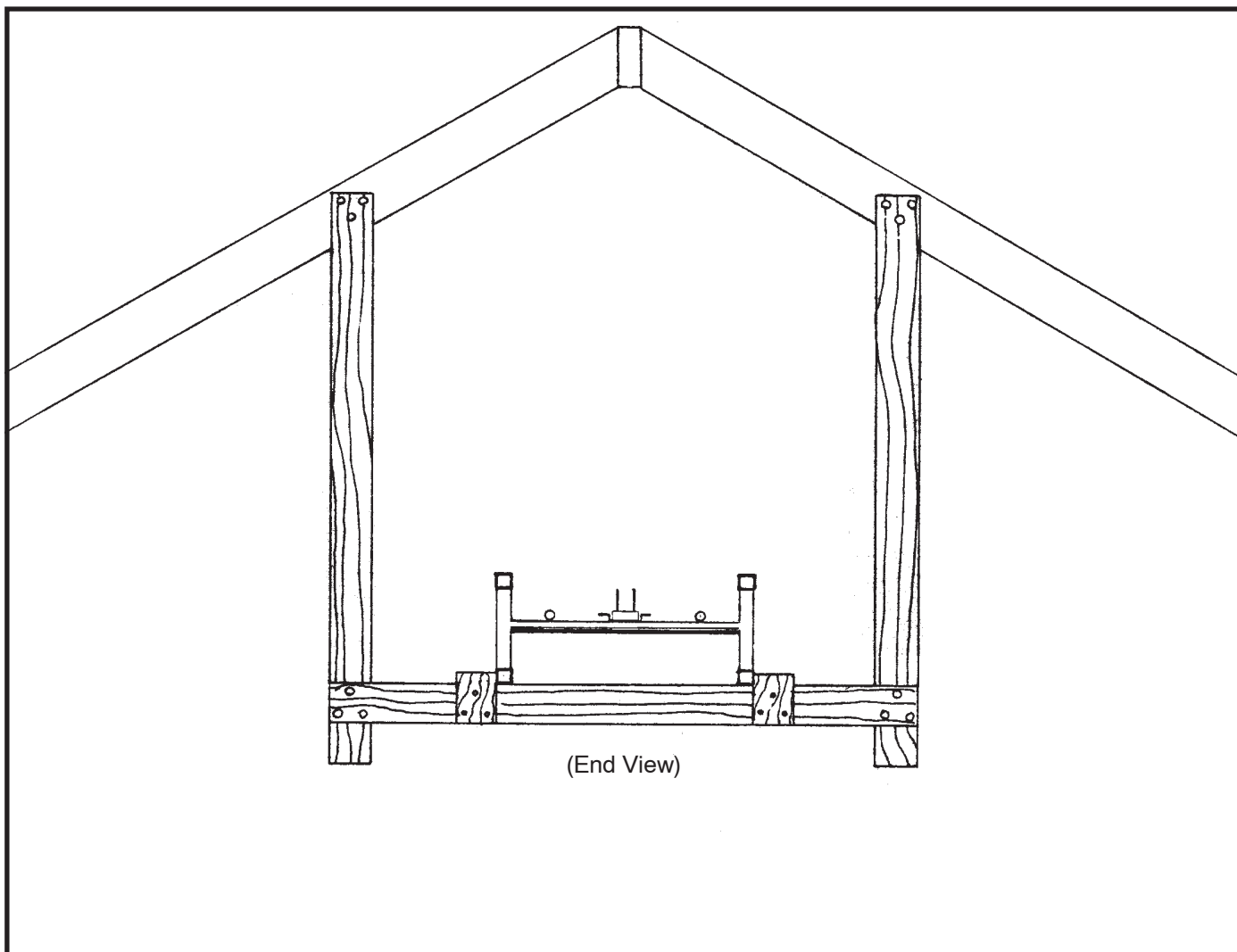

Trouble Shooting Guide

Symptom:

Bales are bunching up at kick-off and not going over the side smoothly.

Symptom:

Bales fall off conveyor before reaching the kick-off.

Problem:

Elevator is not loading bale onto conveyor properly.

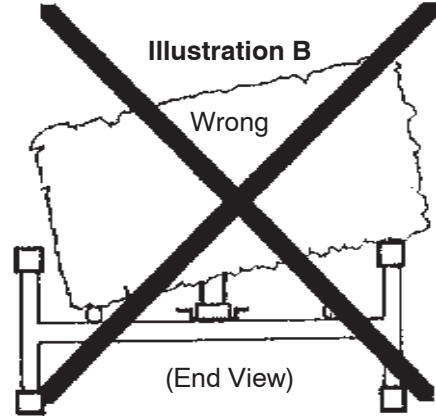
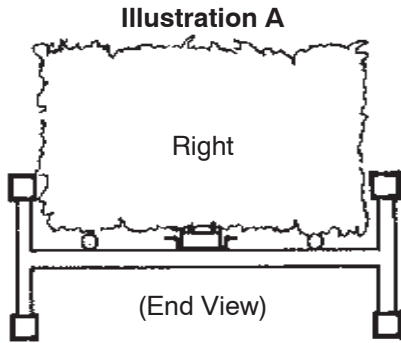

SOLUTION:

Use the accessories shown below.

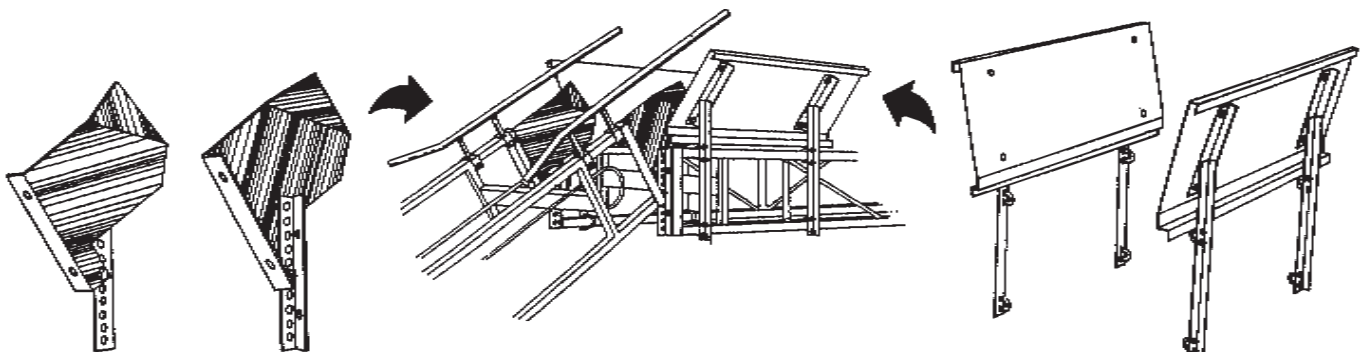

Connector plates: Connects incline elevator to horizontal mow conveyor. Prevents bales from turning and tumbling out when transferring.

Above drawing illustrates incline elevator assembled to horizontal conveyor, using Bale Guides (model HST-7A), Connector Plates (model HST-17A or 18A) and Bale Arrangers (model HST-16A).

Bale arrangers: Directs irregular shaped bales into horizontal conveyor. Made of heavy galvanized steel.

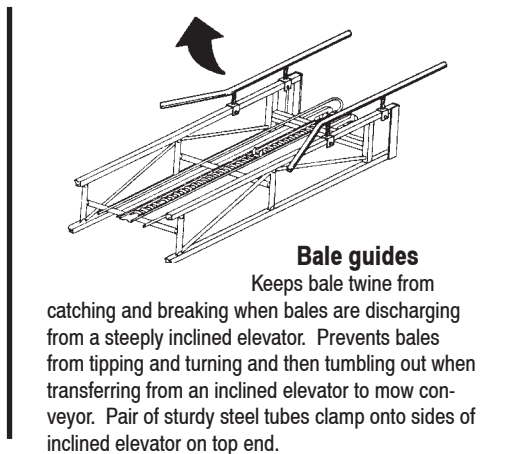

SOLUTION:

Continued on page 27

Trouble Shooting Guide

SOLUTION:

Position the outside elevator to feed bales straight onto the mow conveyor.

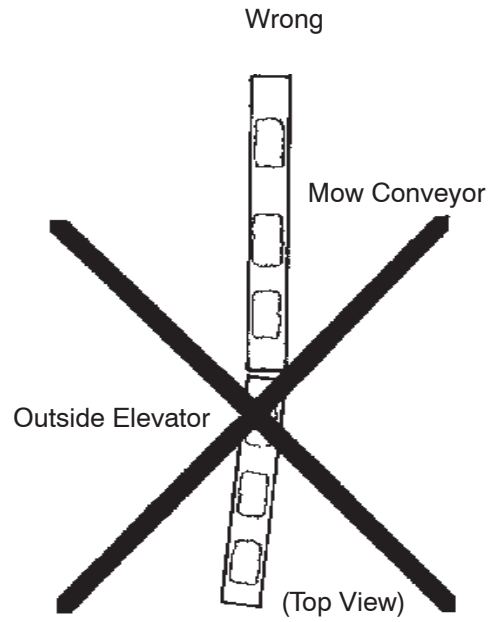
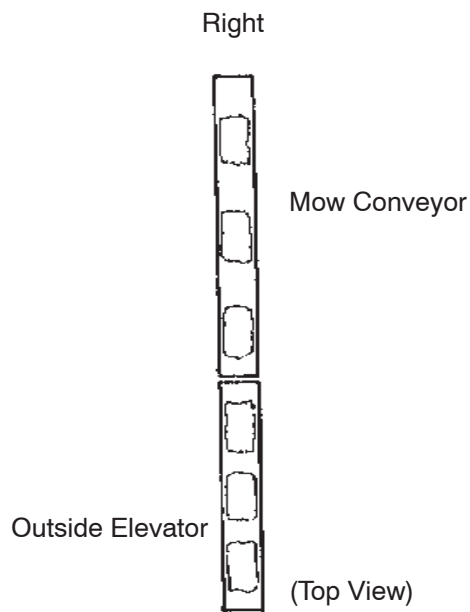

Trouble Shooting Guide

Right

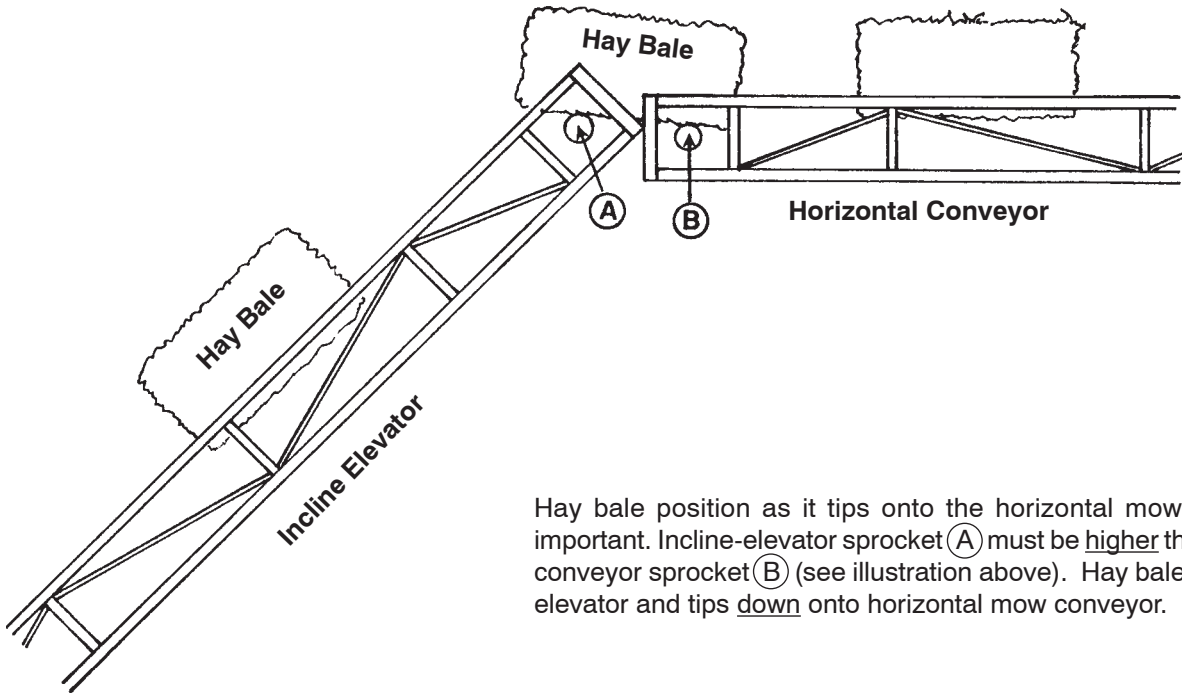

Hay bale position as it tips onto the horizontal mow conveyor is very important. Incline-elevator sprocket (A) must be higher than horizontal mow conveyor sprocket (B) (see illustration above). Hay bale travels up incline-elevator and tips down onto horizontal mow conveyor.

Wrong

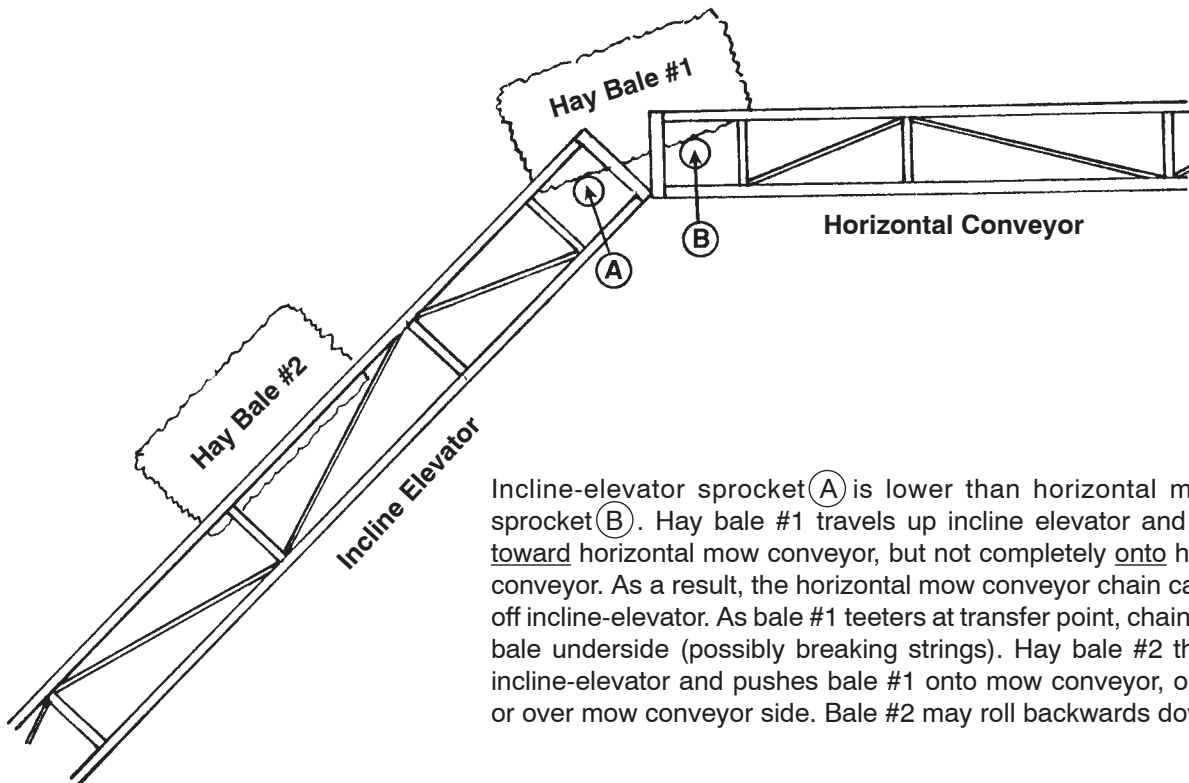

Incline-elevator sprocket (A) is lower than horizontal mow conveyor sprocket (B). Hay bale #1 travels up incline elevator and tips part way toward horizontal mow conveyor, but not completely onto horizontal mow conveyor. As a result, the horizontal mow conveyor chain cannot pull bale off incline-elevator. As bale #1 teeters at transfer point, chains spin through bale underside (possibly breaking strings). Hay bale #2 then travels up incline-elevator and pushes bale #1 onto mow conveyor, or up in the air, or over mow conveyor side. Bale #2 may roll backwards down elevator.

Service and Maintenance



**Failure to heed these instructions
can result in personal injury.**

Never service elevator while running or with power source connected. Disconnect and lock out power source before adjusting or servicing to prevent unexpected application of power.

Always replace all safety shields, guards and covers before restarting elevator.

Lubrication Instructions

As with any type of equipment, the life of the unit is dependent upon the lubrication care given by the operator. Lubrication should be done at regular intervals to avoid premature failure. Service of the complete unit should take place if the machine has been allowed to set for a period of time.

Bearing Lubrication:

All bronze pillow block bearings on drive unit have grease zerks. They should be greased every 15 hours and checked for looseness or seizing to shaft. Extend life by scheduled greasing.

Chain Lubrication:

Pour a light stream of heavy oil onto the elevator chain. Oil will reduce friction, quiet elevator and greatly extend chain life. Lubricate the drive roller chain with SAE 90 gear lube. It clings and gives excellent lubrication.

Preventative Maintenance Check List

Although this type of equipment has few lubrication points (see “Lubrication Instructions”), there are certain areas that should be inspected daily which will aid the operator in preventing needless breakdowns in the machine. Following is a “Check List” of these areas.

1. Inspect all bearings. Faulty bearings can cause damage to the entire unit. Replace if noisy, loose or damaged.
2. Inspect conveyor chain for worn or broken links. Replace if necessary.
3. Inspect drive chain and belt for proper alignment and wear. Replace if necessary.
4. Check all hardware and make sure all are tightened securely.
5. Keep electric motors and motor fans clean of hay and dust. This will allow motor to cool properly.

OPERATING HEIGHTS & GENERAL DIMENSIONS

Safety Cable Removed for Display Purposes Only

TOWING ANGLE

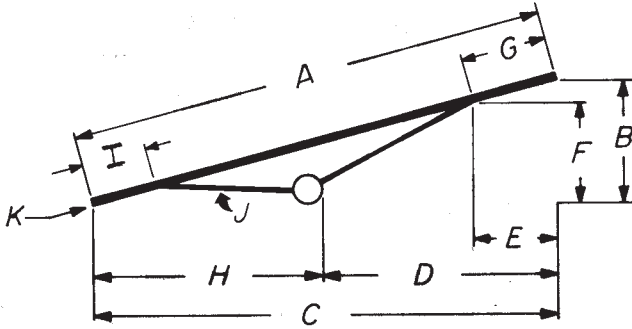

30° ANGLE

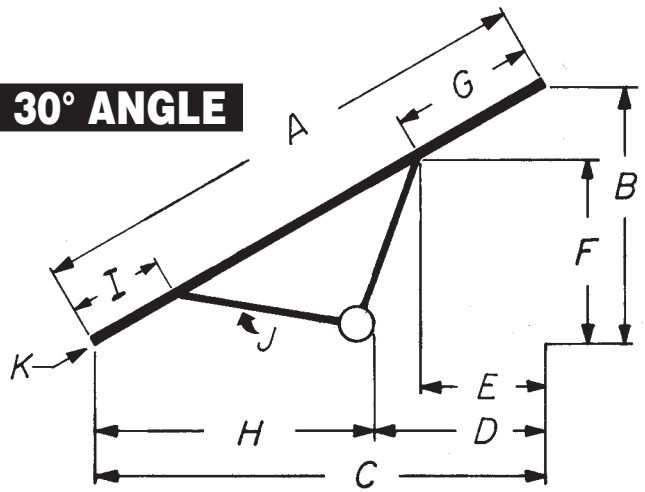

35° ANGLE

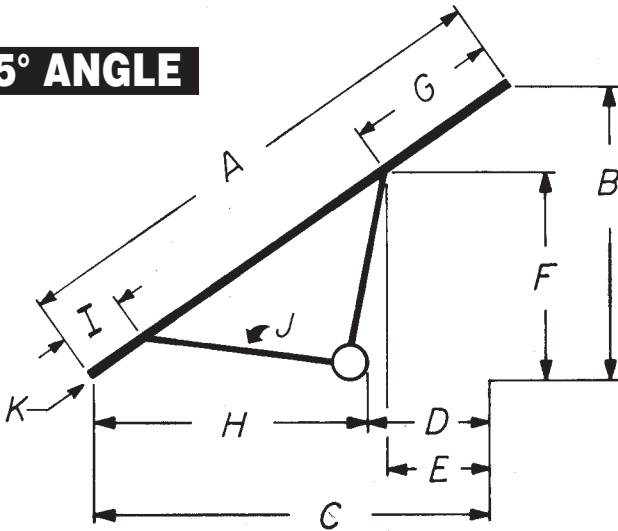

40° ANGLE

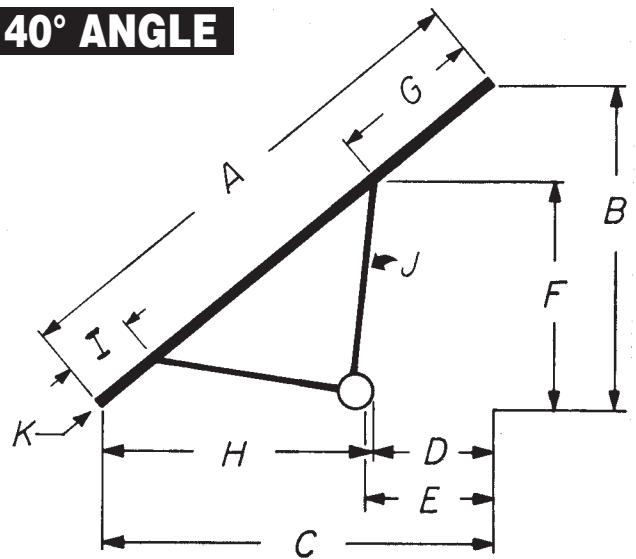

45° ANGLE

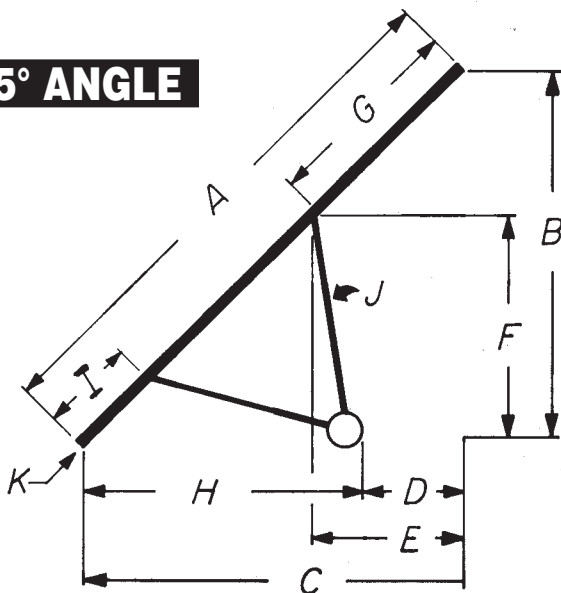

TRANSPORT AXLE WIDTH

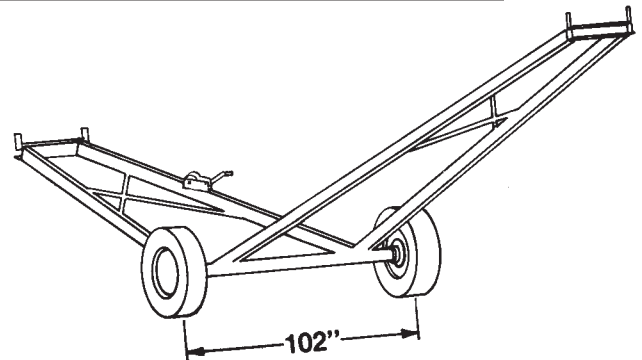

(From center of tire to center of tire - outside width will vary depending on tire width)

<i>Elevator Length</i>	<i>Discharge Height</i>	<i>Reach</i>	<i>Wheel to Wall</i>	<i>Eave Clearance</i>	<i>Free Clearance</i>	<i>Elevator Overhang</i>	<i>Wheel to Elevator End</i>	<i>Elevator End to Transport Mount</i>	<i>Leg</i>	<i>Weight at Hitch, including Motor & Bale Chute</i>
A	B	C	D	E	F	G	H	I	J	K
TOWING ANGLE — Model HST-10T Transport										
20'	7' 7"	18' 11"	6' 10"	0' 10"	6' 3"	1' 5"	12' 1"	2' 7"	9' 0"	161 lbs.
24'	9' 1"	22' 8"	10' 7"	4' 7"	6' 3"	5' 4"	12' 1"	2' 7"	9' 0"	124 lbs.
28'	10' 4"	26' 6"	14' 5"	8' 5"	6' 3"	9' 5"	12' 1"	2' 7"	9' 0"	81 lbs.
30'	10' 5"	28' 6"	15' 6"	9' 4"	6' 3"	10' 7"	13' 0"	3' 6"	9' 0"	70 lbs.
32'	10' 4"	30' 7"	16' 11"	10' 9"	6' 1"	11' 9"	13' 9"	4' 3"	9' 0"	71 lbs.
TOWING ANGLE — Model HST-20T Transport										
36'	10' 3"	34' 11"	16' 6"	2' 7"	8' 1"	4' 10"	18' 5"	2' 7"	15' 0"	140 lbs.
40'	10' 10"	38' 10"	19' 8"	6' 3"	8' 1"	8' 3"	19' 2"	3' 4"	15' 0"	116 lbs.
42'	11' 3"	40' 9"	21' 4"	8' 11"	7' 11"	9' 9"	19' 5"	3' 7"	15' 0"	97 lbs.
44'	11' 2"	42' 10"	22' 5"	9' 10"	7' 8"	11' 0"	20' 6"	4' 8"	15' 0"	98 lbs.
48'	11' 2"	47' 1"	24' 11"	12' 1"	6' 10"	13' 0"	22' 3"	6' 5"	15' 0"	85 lbs.
TOWING ANGLE — Model HST-40T Transport										
54'	11' 1"	53' 2"	26' 2"	8' 2"	7' 11"	9' 0"	27' 0"	6' 0"	20' 0"	135 lbs.
60'	11' 7"	59' 1"	31' 1"	13' 1"	8' 1"	14' 3"	28' 0"	7' 0"	20' 0"	81 lbs.
30° ANGLE — Model HST-10T Transport										
20'	10' 0"	17' 4"	5' 5"	2' 2"	8' 9"	2' 6"	11' 11"	2' 7"	9' 0"	184 lbs.
24'	12' 0"	20' 9"	8' 11"	5' 8"	8' 9"	6' 6"	11' 11"	2' 7"	9' 0"	158 lbs.
28'	14' 0"	24' 3"	12' 4"	9' 2"	8' 9"	10' 6"	11' 11"	2' 7"	9' 0"	120 lbs.
30'	15' 0"	26' 0"	13' 4"	10' 6"	8' 11"	12' 1"	12' 8"	3' 6"	9' 0"	115 lbs.
32'	16' 0"	27' 9"	14' 5"	11' 11"	9' 1"	13' 10"	13' 3"	4' 3"	9' 0"	112 lbs.
30° ANGLE — Model HST-20T Transport										
36'	18' 0"	31' 2"	13' 0"	6' 7"	14' 3"	7' 7"	18' 2"	2' 7"	15' 0"	205 lbs.
40'	20' 0"	34' 8"	15' 10"	9' 8"	14' 5"	11' 2"	18' 9"	3' 4"	15' 0"	178 lbs.
42'	21' 0"	36' 4"	17' 4"	11' 4"	14' 6"	13' 1"	19' 0"	3' 7"	15' 0"	170 lbs.
44'	22' 0"	38' 1"	18' 3"	12' 8"	14' 8"	14' 7"	19' 11"	4' 8"	15' 0"	167 lbs.
48'	24' 0"	41' 7"	20' 3"	15' 6"	15' 1"	17' 10"	21' 4"	6' 5"	15' 0"	160 lbs.
30° ANGLE — Model HST-40T Transport										
54'	27' 0"	46' 9"	20' 7"	12' 11"	19' 7"	14' 11"	26' 2"	6' 0"	20' 0"	225 lbs.
60'	30' 0"	52' 0"	25' 0"	17' 10"	19' 8"	20' 8"	27' 0"	7' 0"	20' 0"	190 lbs.
35° ANGLE — Model HST-10T Transport										
20'	11' 6"	16' 5"	4' 7"	3' 0"	9' 5"	3' 7"	11' 9"	2' 7"	9' 0"	199 lbs.
24'	13' 9"	19' 8"	7' 11"	6' 3"	9' 5"	7' 7"	11' 9"	2' 7"	9' 0"	180 lbs.
28'	16' 1"	22' 11"	11' 2"	9' 6"	9' 5"	11' 7"	11' 9"	2' 7"	9' 0"	141 lbs.
30'	17' 3"	24' 7"	12' 1"	10' 11"	9' 7"	13' 4"	12' 6"	3' 6"	9' 0"	137 lbs.
32'	18' 4"	26' 3"	13' 2"	12' 5"	9' 8"	15' 2"	13' 0"	4' 3"	9' 0"	132 lbs.
35° ANGLE — Model HST-20T Transport										
36'	20' 8"	29' 6"	11' 6"	7' 7"	15' 4"	9' 3"	18' 0"	2' 7"	15' 0"	240 lbs.
40'	22' 11"	32' 9"	14' 2"	10' 8"	15' 6"	13' 0"	18' 7"	3' 4"	15' 0"	215 lbs.
42'	24' 1"	34' 5"	15' 7"	12' 3"	15' 6"	14' 11"	18' 10"	3' 7"	15' 0"	208 lbs.
44'	25' 3"	36' 0"	16' 5"	13' 7"	15' 9"	16' 7"	19' 8"	4' 8"	15' 0"	200 lbs.
48'	27' 6"	39' 4"	18' 4"	16' 7"	15' 11"	20' 3"	20' 11"	6' 5"	15' 0"	188 lbs.
35° ANGLE — Model HST-40T Transport										
54'	31' 0"	44' 3"	18' 4"	14' 6"	20' 9"	17' 9"	25' 10"	6' 0"	20' 0"	272 lbs.
60'	34' 5"	49' 2"	22' 7"	19' 4"	20' 11"	23' 7"	26' 7"	7' 0"	20' 0"	230 lbs.
40° ANGLE — Model HST-10T Transport										
20'	12' 10"	15' 4"	3' 8"	3' 8"	9' 9"	4' 10"	11' 8"	2' 7"	9' 0"	216 lbs.
24'	15' 5"	18' 5"	6' 9"	6' 9"	9' 9"	8' 10"	11' 8"	2' 7"	9' 0"	200 lbs.
28'	18' 0"	21' 5"	9' 10"	9' 10"	9' 9"	12' 10"	11' 8"	2' 7"	9' 0"	162 lbs.
30'	19' 3"	23' 0"	10' 9"	11' 3"	9' 10"	14' 9"	12' 3"	3' 6"	9' 0"	160 lbs.
32'	20' 7"	24' 6"	11' 9"	13' 0"	10' 9"	16' 11"	12' 9"	4' 3"	9' 0"	154 lbs.
40° ANGLE — Model HST-20T Transport										
36'	23' 2"	27' 7"	9' 8"	8' 6"	16' 0"	11' 1"	17' 11"	2' 7"	15' 0"	261 lbs.
40'	25' 9"	30' 8"	12' 3"	11' 6"	16' 1"	15' 0"	18' 5"	3' 4"	15' 0"	248 lbs.
42'	27' 0"	32' 2"	13' 7"	13' 0"	16' 1"	17' 0"	18' 7"	3' 7"	15' 0"	240 lbs.
44'	28' 3"	33' 9"	14' 4"	14' 6"	16' 2"	18' 11"	19' 4"	4' 8"	15' 0"	235 lbs.
48'	30' 10"	36' 9"	16' 3"	17' 11"	17' 3"	23' 4"	20' 6"	6' 5"	15' 0"	226 lbs.
40° ANGLE — Model HST-40T Transport										
54'	34' 9"	41' 4"	15' 10"	16' 0"	21' 4"	20' 10"	25' 6"	6' 0"	20' 0"	312 lbs.
60'	38' 7"	46' 0"	19' 10"	20' 7"	21' 4"	26' 10"	26' 2"	7' 0"	20' 0"	270 lbs.
45° ANGLE — Model HST-10T Transport										
20'	14' 2"	14' 2"	2' 8"	4' 6"	11' 5"	6' 5"	11' 5"	2' 7"	9' 0"	239 lbs.
24'	17' 0"	17' 0"	5' 6"	7' 4"	11' 5"	10' 5"	11' 5"	2' 7"	9' 0"	228 lbs.
28'	19' 10"	19' 10"	8' 4"	10' 2"	11' 5"	14' 5"	11' 5"	2' 7"	9' 0"	197 lbs.
30'	21' 3"	21' 3"	9' 2"	11' 7"	12' 0"	16' 4"	12' 0"	3' 6"	9' 0"	181 lbs.
32'	22' 8"	22' 8"	10' 2"	13' 2"	12' 6"	18' 8"	12' 6"	4' 3"	9' 0"	173 lbs.
45° ANGLE — Model HST-20T Transport										
36'	25' 6"	25' 6"	7' 9"	9' 7"	17' 9"	13' 7"	17' 9"	2' 7"	15' 0"	300 lbs.
40'	28' 3"	28' 3"	10' 1"	12' 5"	18' 3"	17' 7"	18' 3"	3' 4"	15' 0"	287 lbs.
42'	29' 8"	29' 8"	11' 4"	13' 10"	18' 5"	19' 7"	18' 5"	3' 7"	15' 0"	280 lbs.
44'	31' 1"	31' 1"	12' 1"	15' 5"	19' 1"	21' 9"	19' 1"	4' 8"	15' 0"	277 lbs.
48'	33' 11"	33' 11"	13' 11"	18' 6"	20' 1"	26' 2"	20' 1"	6' 5"	15' 0"	270 lbs.
45° ANGLE — Model HST-40T Transport										
54'	38' 2"	38' 2"	13' 1"	17' 5"	25' 1"	25' 7"	25' 1"	6' 0"	20' 0"	352 lbs.
60'	42' 5"	42' 5"	16' 9"	21' 9"	25' 8"	30' 9"	25' 8"	7' 0"	20' 0"	323 lbs.

LAYOUT GUIDE

BALE HANDLING SYSTEMS

For each Reference No. (#) below, refer to related Reference No. (#) on layout illustrations below.

- Reference No.** **Component Description and (Model No.)**
- ① Transport Hitch (*HST-10A or HST-15A*)
 - ② Bale Chute (*HST-5A or HST-12A*)
 - ③ Drive Unit and Electric Motor Location
 - ④ Transport (*HST-10T, HST-20T or HST-40T*)

- ⑤ Bale Guides (*HST-7A*)
- ⑥ Connector Plates (*HST-17A or HST-18A*)
- ⑦ Bale Arrangers (*HST-16A*)
- ⑩ Mow Hanger Chain Kit (*HST-2A*)
- ⑪ Automatic Bale Kick-off (*HST-1A or HST-13A*)

Reference No. **Component Description and (Model No.)**

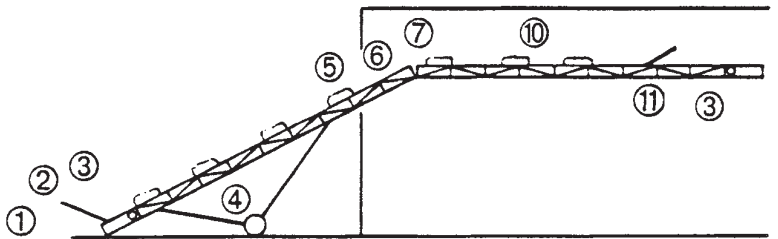
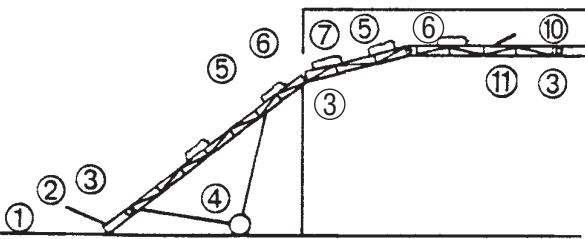
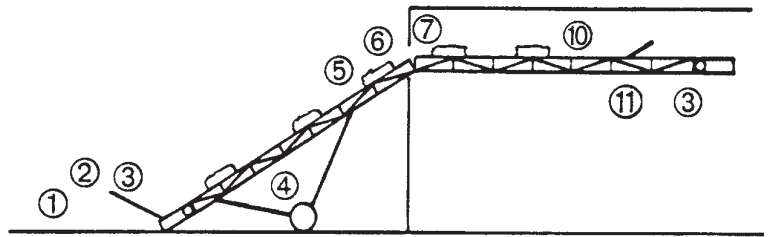
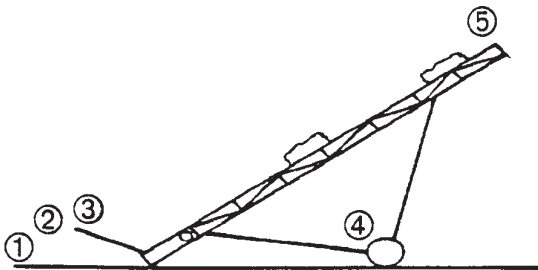

LAYOUT GUIDE

BALE HANDLING SYSTEMS

For each Reference No. (#) below, refer to related Reference No. (#) on layout illustrations below.

- | | | | |
|----------------------|--|---|---|
| Reference No. | Component Description and (Model No.) | ⑤ | Bale Guides (HST-7A) |
| ① | Transport Hitch (HST-10A or HST-15A) | ⑥ | Connector Plates (HST-17A or HST-18A) |
| ② | Bale Chute (HST-5A or HST-12A) | ⑦ | Bale Arrangers (HST-16A) |
| ③ | Drive Unit and Electric Motor Location | ⑩ | Mow Hanger Chain Kit (HST-2A) |
| ④ | Transport (HST-10T, HST-20T or HST-40T) | ⑪ | Automatic Bale Kick-off (HST-1A or HST-13A) |

Reference No. **Component Description and (Model No.)**

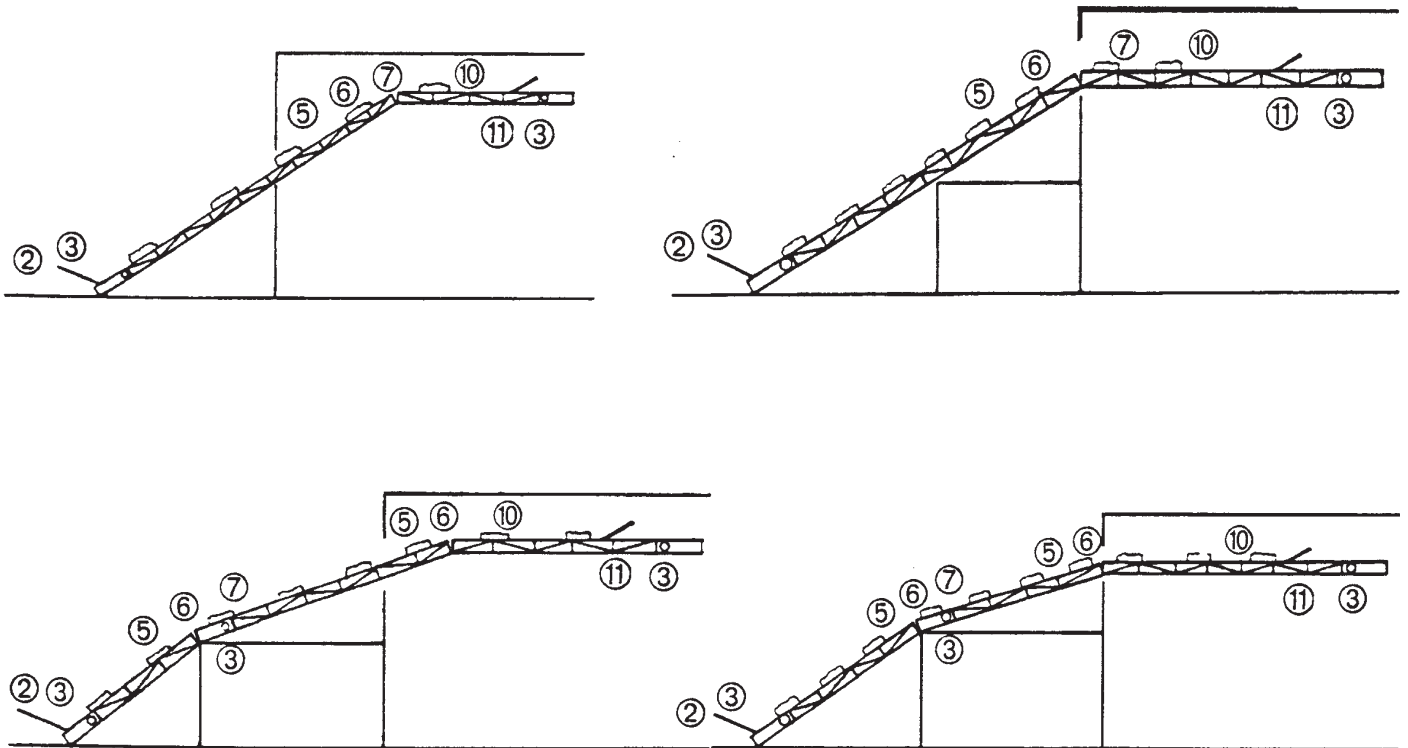

HAY CONVEYOR (Model HEC) – Parts List

KEY NO.	DESCRIPTION	NEW PART NO.	NO. REQUIRED
1	NUT,NY-IN LOCK,5/16-18,G2,PLT	F356040	5
2	CLAMP,EHD/HEC ELEV MOTOR MOUNT	70500	2
3	PIPE,HEC BALE ELEV MOTOR MOUNT	HEC-00003	1
4	HHCS,5/16-18 X 3",G5,PLT	F1072375	4
5	BEARING W/STRAIGHT ZERK,FLANGE,1"ID	FAH16G	4
6	WASHER,SPRING LOCK,5/16",PLT	F805050	20
7	NUT,HEX,5/16-18,G5,PLT	F354040	20
9	BUSHING,MACH,18 X 1-1/32" X 1-1/2",UPLT	F806060	6
10	SPROCKET,HEC,#55 X 7T X 1"ID	HEC-000010	1
11	PIN,ROLL,5/16 X 1-7/8",PLT	F407055	1
13	PIN,ROLL,5/16 X 1-1/2",PLT	F407050	1
14	WASHER,STD FL,5/16",PLT	F808030	18
15	TIGHTENER,NYLON ROLLER CHAIN	70449	1
16	HHCS,5/16-18 X 1-3/4",G5,PLT	F1072357	1
17	NUT,HEX,3/8-16,G5,PLT	F354050	10
18	WASHER,SPRING LOCK,3/8",PLT	F805060	4
19	HHCS,3/8-16 X 1",G5,PLT	F1072450	4
20	FRAME W/SHAFT & SPROCKET,DRIVE,8'	70420	1
21	ARM,ELEV MOTOR MOUNT ADJUSTING	70431	2
22	HHCS,5/16-18 X 1",G5,PLT	F1072345	4
23	SS,SK-HD,K-P,5/16-18 X 3/8",G2,UPLT	F702037	1 **
24	V-BELT,TYPE A,4L450	4L450	1
25	PULLEY,12" X 1"BORE	70519	1
26	SPROCKET W/SHAFT,HEC,#40 X 12T X 1"	HEC-000026	1
27	LINK W/PIN&CLIP,ROLL CHAIN,#40	N0401	1
28	CHAIN W/LINK,ROLLER,#40 X 62 PITCH	70016	1
29	SPROCKET W/SHAFT,HEC,#40 X 50T X 1"	HEC-000029	1
30	TUBE,RD,DOM,11/64" X 1-3/8" X 1/2"L	70976	2
31	HHCS,5/16-18 X 3/4",G5,PLT	F1072340	8
32	NUT,WING,3/8-16,G2,PLT	F358080	1
33	COVER W/DECALS,HEC/EHD SHIELD	70448	1 *
34	NUT,NY-IN LOCK,1/4-20,G2,PLT	F356030	8
35	HHCS,1/4-20 X 1-1/2",G5,PLT	F1072255	6
36	SHIELD,HEC FRAME(UPPER)	HEC-000036	1 *
37	SHIELD,HEC/EHD FRAME(LOWER)	70447	1 *
38	HHCS,1/4-20 X 3/4",G5,PLT	F1072245	2
39	SHAFT,HEC BALE ELEVATOR IDLER	HEC-000039	1
40	HH TAP BOLT,3/8-16 X 3-1/2",G2,PLT	F108555	2
42	SPROCKET, CAST IDLER, #55 x 6-TOOTH X .755"	INCLUDED IN KEY NO. 55	1
43	CHAIN W/RAISED LINK,BALE,#55,1'	HC551	-
44	LINK, BALE ELEV #55 RAISED	HB4-55	-
45	IDLER L/PARTS BOX, HEC ELEV,8'	HEC-8I-LPB	1
46	DECAL,WARNING-BEFORE STARTING	11096	1 *
48	DECAL,DANGER-SHIELDS ARE OFF	11097	1 *
49	RETURN,BALE ELEV #55 CHAIN	HEC-000049	2
50	U-BOLT,5/16-18 X 1-3/8" X 2-3/16",G2	F105020	4
51	BUSHING,MACH,18 X 24/32" X 1-1/4",UPLT	F806030	7
52	PIPE,PLASTIC,3/4" X 1-17/32"L (POST 4/15/05)	71014	1
53	MANUAL ASSY,HEC BALE ELEV OWNER	HEC-000053	1 *
54	DECAL,DANGER-FALLING HAY...	DEC101293	1 *
55	SPROCKET W/SPACER & BUSHINGS,#55 X 6-TOOTH X .755"	71013	1

* Specify serial number of elevator

** Not sold separately. Available from your local hardware store.



**Do not substitute Grade 2 bolts when stronger Grade 5 bolts are specified.
Failure to heed could result in personal injury or death!**

Illustration A

DRIVE END

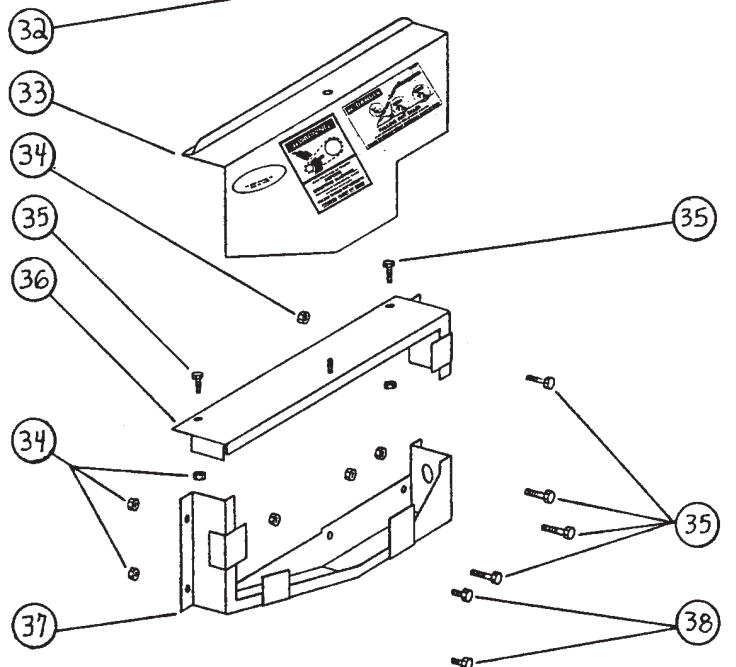
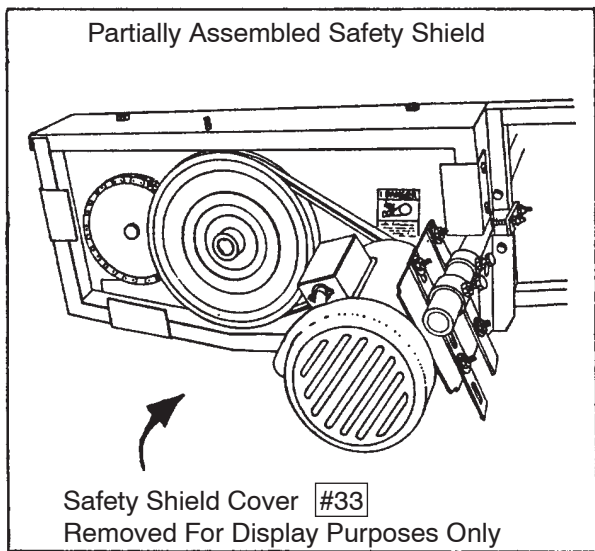
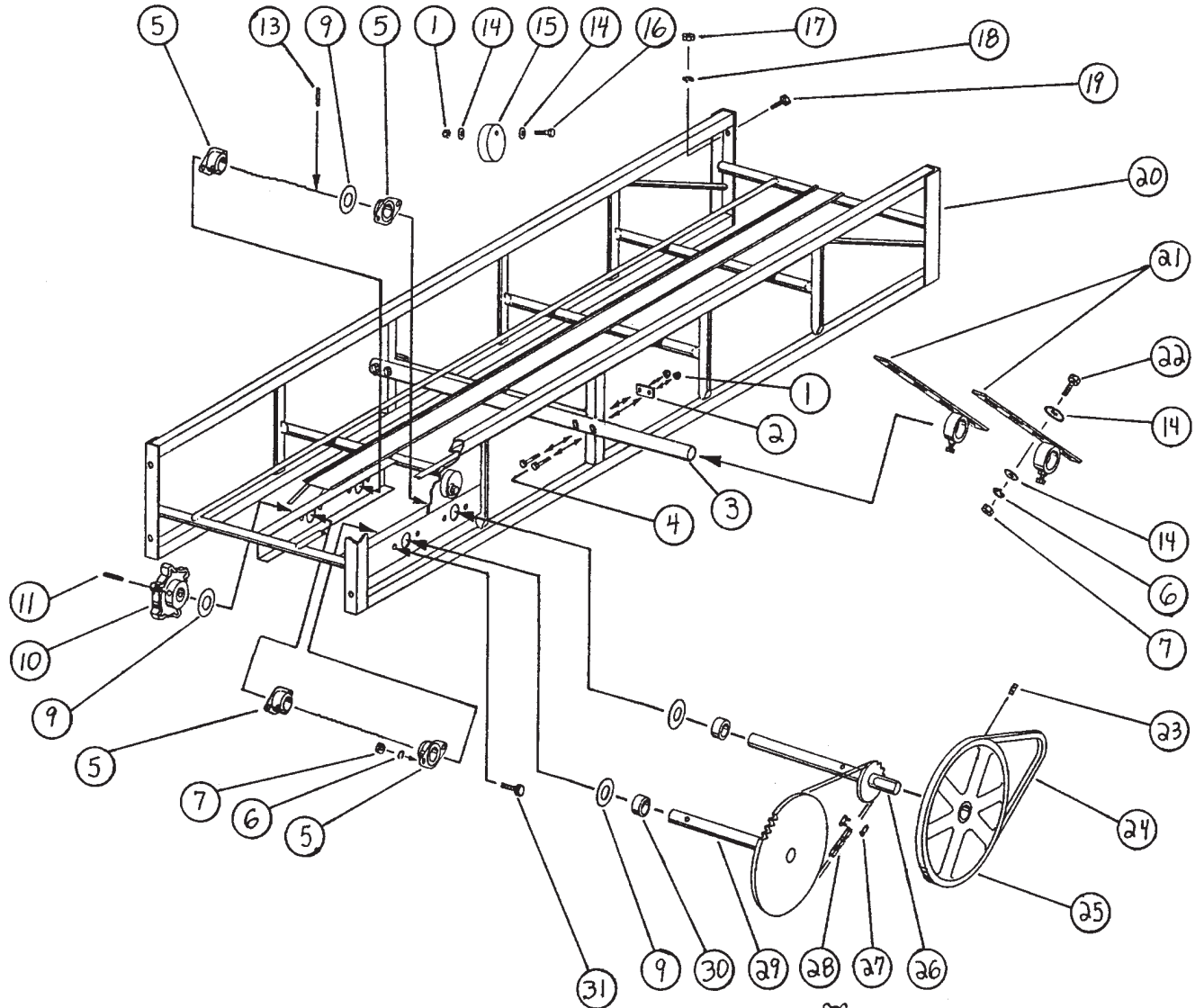

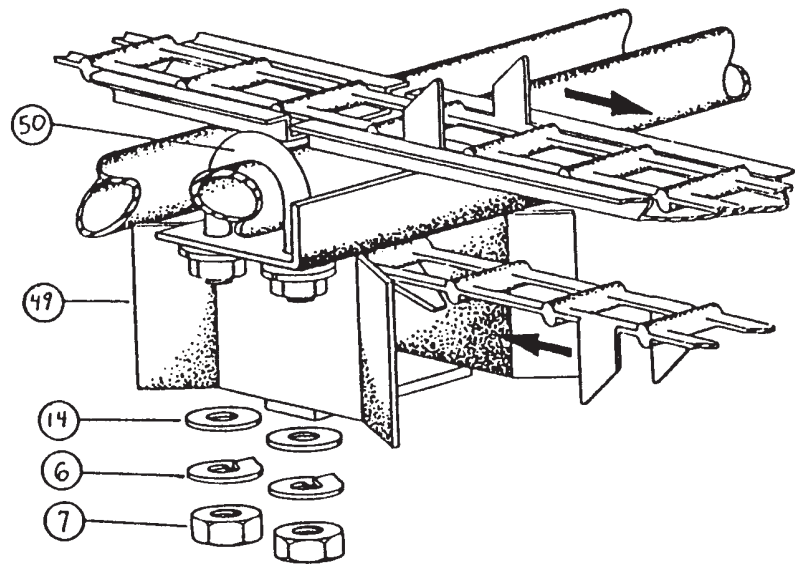
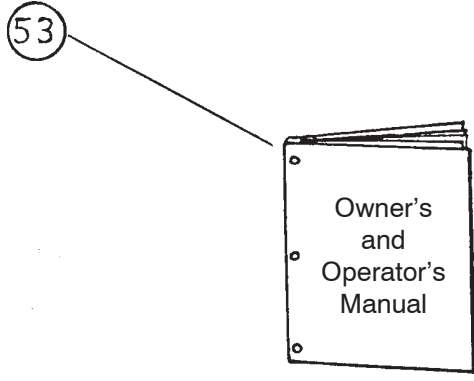

IDLER SECTION

Illustration B

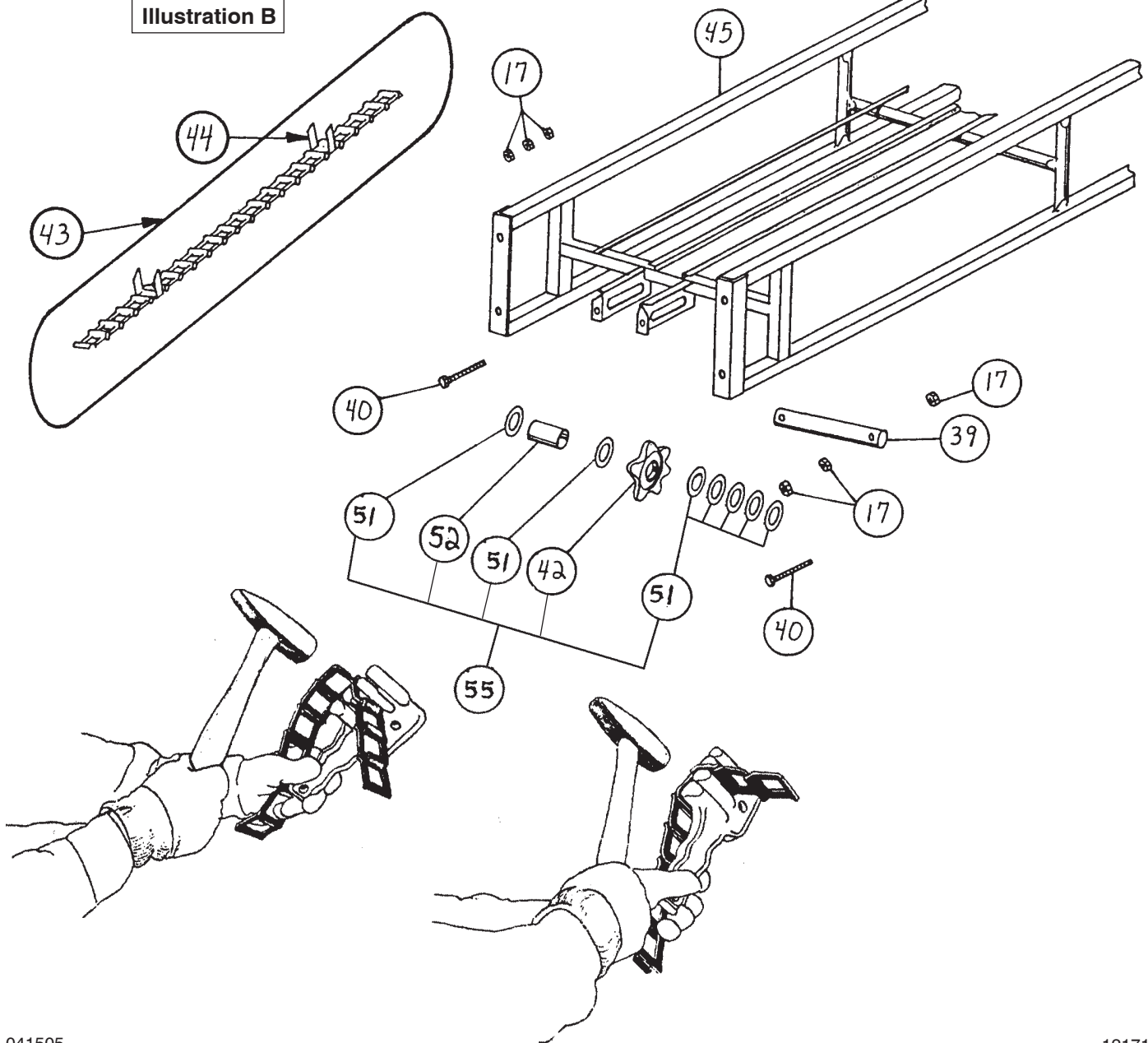

Assembly Instructions

NOTE: For Each # below, refer to related # on enclosed drawing.

Lay out drive section, idler section and extensions. Cut and remove packing and shipping wire. Open cartons and lay out parts so they will be available when needed. Open hardware sacks and group like items.

Each basic 16' elevator (one 8' drive section and one 8' idler section) comes with two red chain returns (see #49 per Illustration C below). Each 8' center extension and 4' center extension comes with one red chain return #49 (refer to Illustration C below).

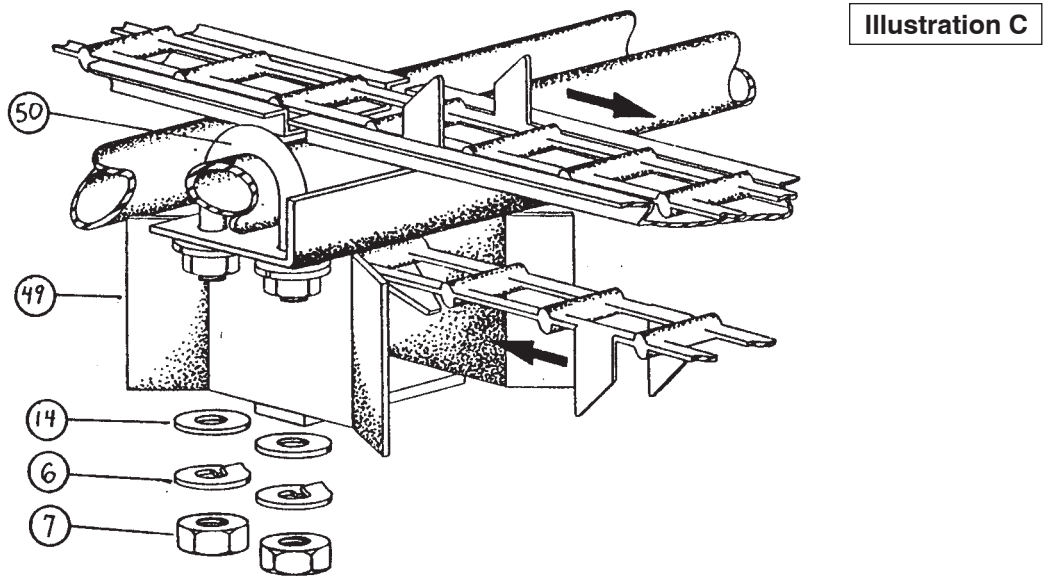

Bolt one red chain return #49, onto underside of 8' drive section, 6' from drive sprocket end (refer to Illustration D below).

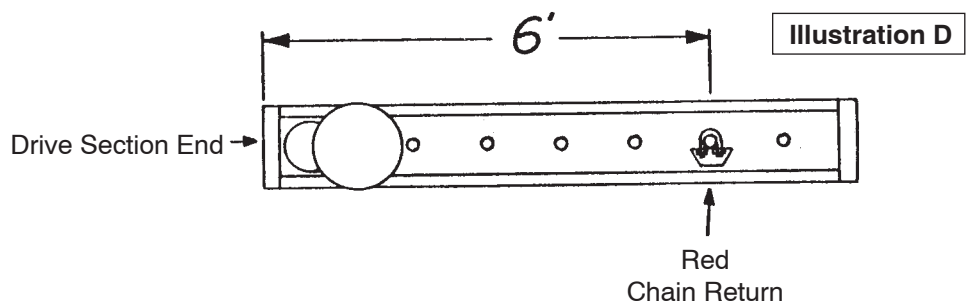

Bolt one red chain return #49 onto underside of 8' idler section, from idler section end (refer to Illustration D-1 below).

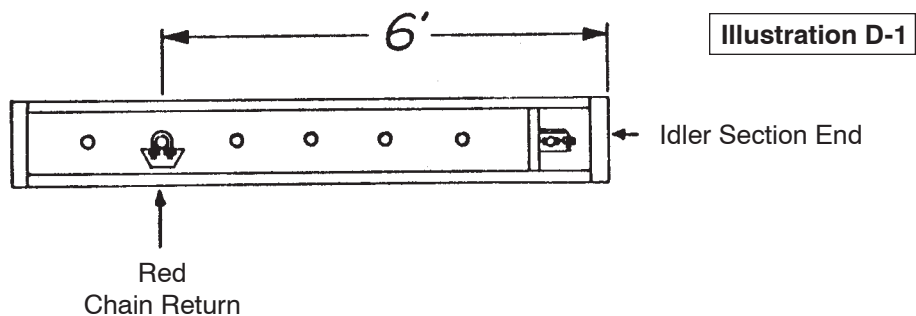

Bolt one red chain return **#49** onto underside of each 8' center extension, 4' from center extension end (refer to illustration D-2 below).

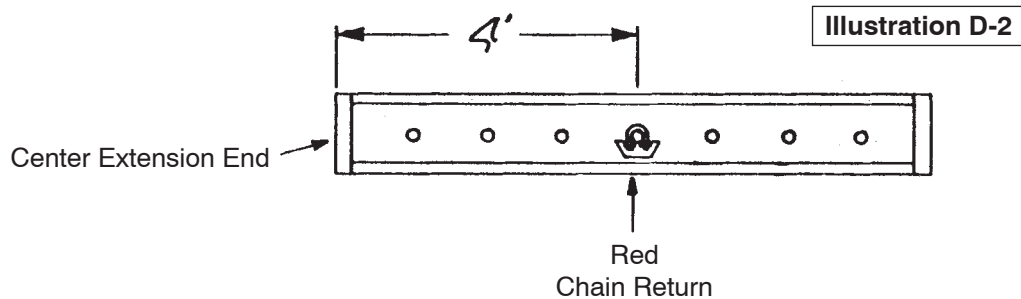

Bolt one red chain return **#49** onto underside of each 4' center extension, 2' from center extension end (refer to illustration D-3 below).

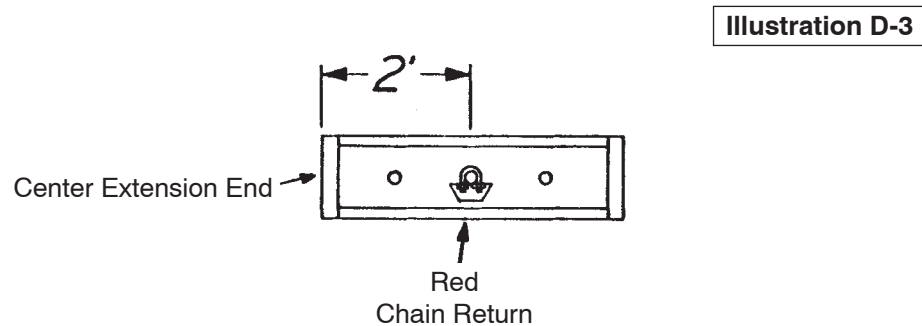

After installing the chain returns, recheck and make sure that:

1. The red chain returns are bolted onto elevator as shown in Illustration C.
2. The first red chain return on 8' drive section is 6' from the drive section end as shown in Illustration D.
3. The last red chain return on 8' idler section is 6' from idler section end as shown in Illustration D-1.
4. The center red chain return on 8' center extension is 4' from center extension end as shown in Illustration D-2.
5. The center red chain return on 4' center extension is 2' from center extension end as shown in Illustration D-3.

Bolt connecting joints on drive section **#20**, extensions and idler section **#45** together using 3/8" x 1" bolts **#19**, 3/8" lockwashers **#18**, and 3/8" nuts **#17**.

Install size 40 roller chain #28 onto headshaft sprocket #29 and jackshaft sprocket #26. If chain appears too short, loosen bearing bolts #31, lockwashers #6 and nuts #7 on outside of elevator. Move headshaft #29 and jackshaft #26 together until chain fits. Splice chain together with connecting link #27. Pull headshaft and jackshaft away from each other until chain is tight. Retighten bearing bolts with chain pulled tight (see illustration below).

Illustration E

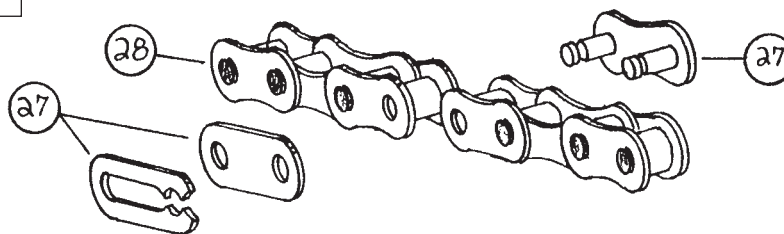

Bolt nylon roller chain tightener slide #15 to one of the two holes on side of drive plate using a 5/16-18 x 3/4" bolt #16, 5/16" flat washer #14 and 5/16" nylon insert lock nut #1. Use the top hole if 60 toother sprocket rotates counter clockwise. Use the bottom hole if 60 tooth sprocket rotates clockwise. When installed, the slack side of nylon roller chain should ride against the nylon roller chain tightener slide. Rotate the nylon roller chain tightener slide until roller chain is snug and then tighten the bolt, flatwasher and nut (see illustrations below).

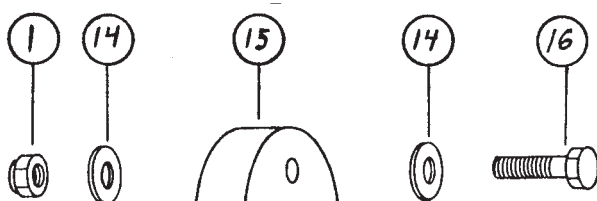
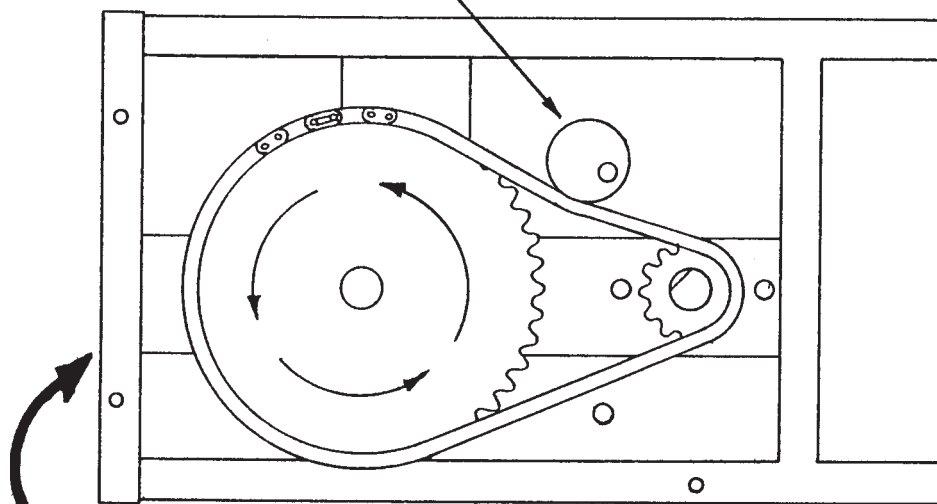

Illustration F



Safety shield removed for display purposes only.

Mount 12" jack pulley #25 onto jackshaft #26 with screw #23. Tighten set screw #23 down onto flat spot on end of jackshaft.

Locate idler shaft #39 , 3/8" nuts #17 , 3/8 x 3 1/2" bolts #40 , 24/32 x 1 1/4" bushings #51 , idler sprocket #42 , and spacer #52 . Assemble into idler section end #45 (see Illustration G and H below).

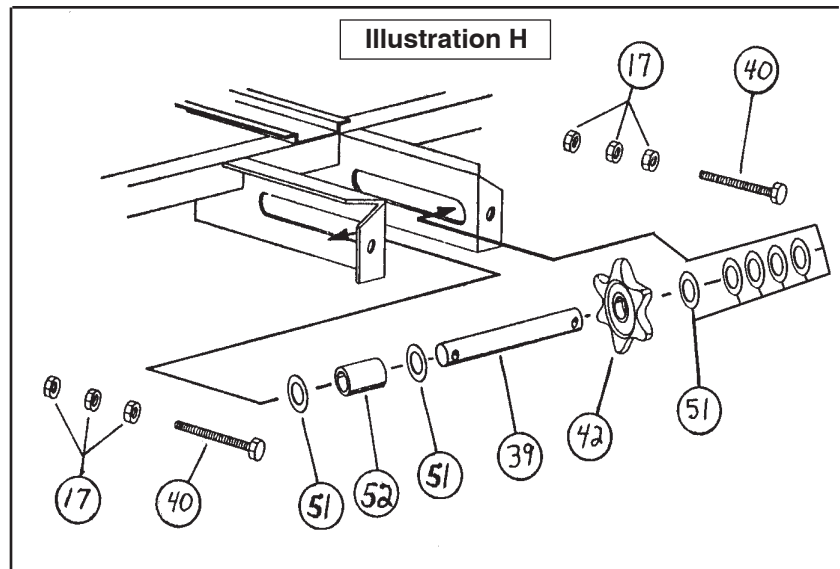
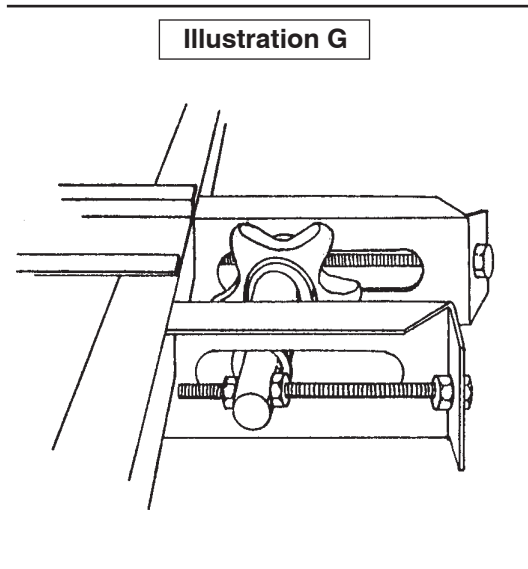

Lay out the conveyor chain #43 in the chain guide tray of elevator. The straight side of the raised link #44 should be pushing the bales (refer to Illustration I below).

Illustration I

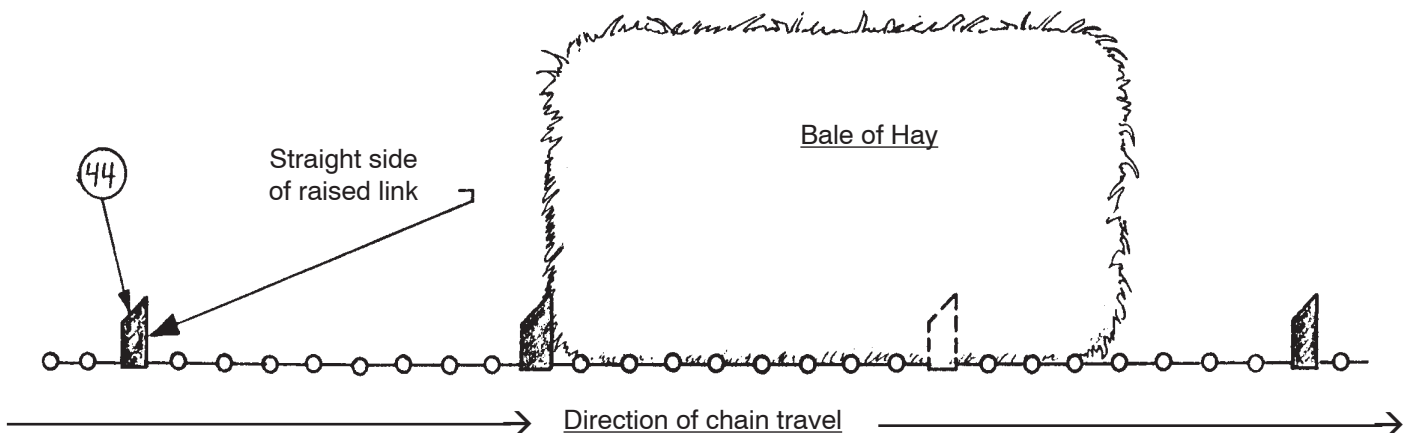

The chain can then be assembled and fished through the red chain returns on bottom of elevator. Connect and tighten chain until snug.

Chain is properly tightened if on 18 ft. unit it can be easily raised about 4" at center with your hand; on 24 ft. unit, 5", etc. If the steel detachable chain is tightened too tight, the elevator will run rough. If the chain is not tightened enough, it may catch during operation.

It is important when tightening chain, to first remove all extra links before using chain tightener. Failure to tighten chain in above order will result in chain tightener not being able to take up all of the slack chain, which is important if the chain is to function properly.

Install the motor mount pipe **#3** onto the drive framework **#20** using the clamp plates **#2**, 5/16" x 3" bolts **#4** and 5/16" nylon insert lock nuts **#1** as shown in illustration below.

Illustration J

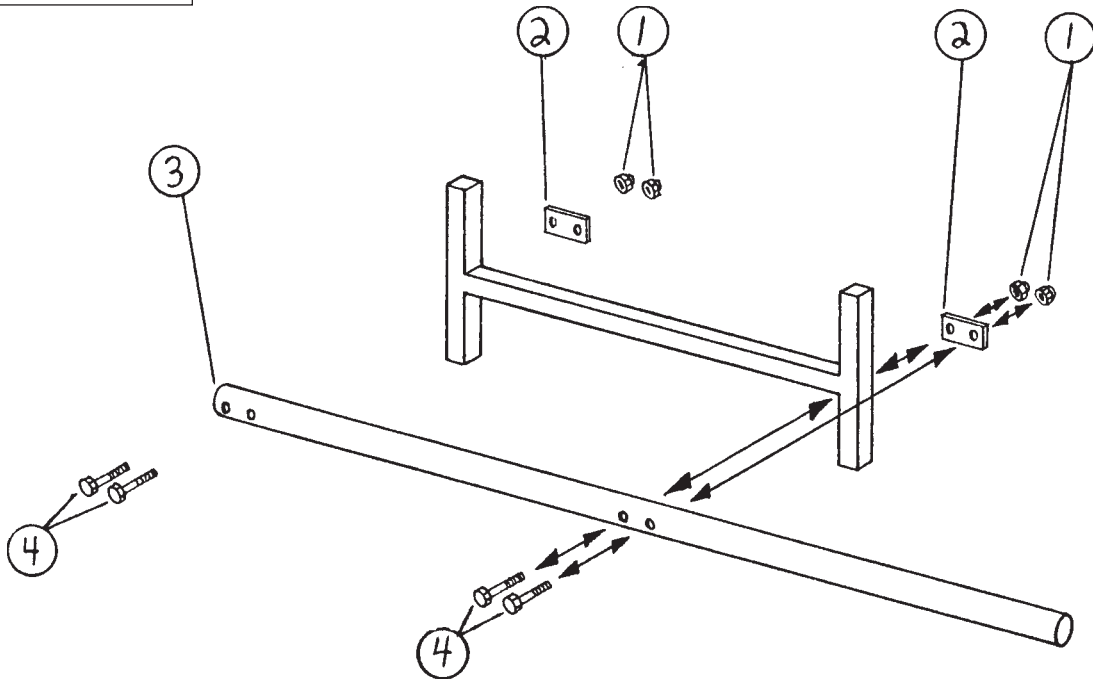

It is important that the motor mount pipe be installed as shown below so as to assure proper fitting of shield.

Illustration K

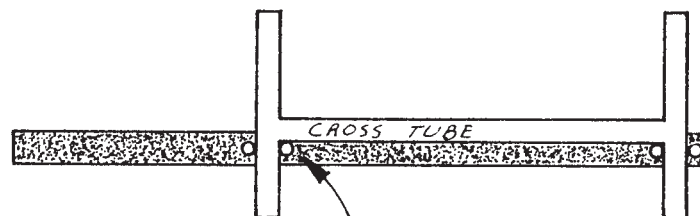

Check and make sure that the 5/16" x 3" bolts are pressed tight against the bottom side of cross tube.

Install lower shield #37 onto the elevator using the 1/4" x 1 1/2" bolts #35, 1/4" x 3/4" bolts #38 and 1/4" locknuts #34 (See illustration below).

Safety shield removed for display purposes only

Illustration L

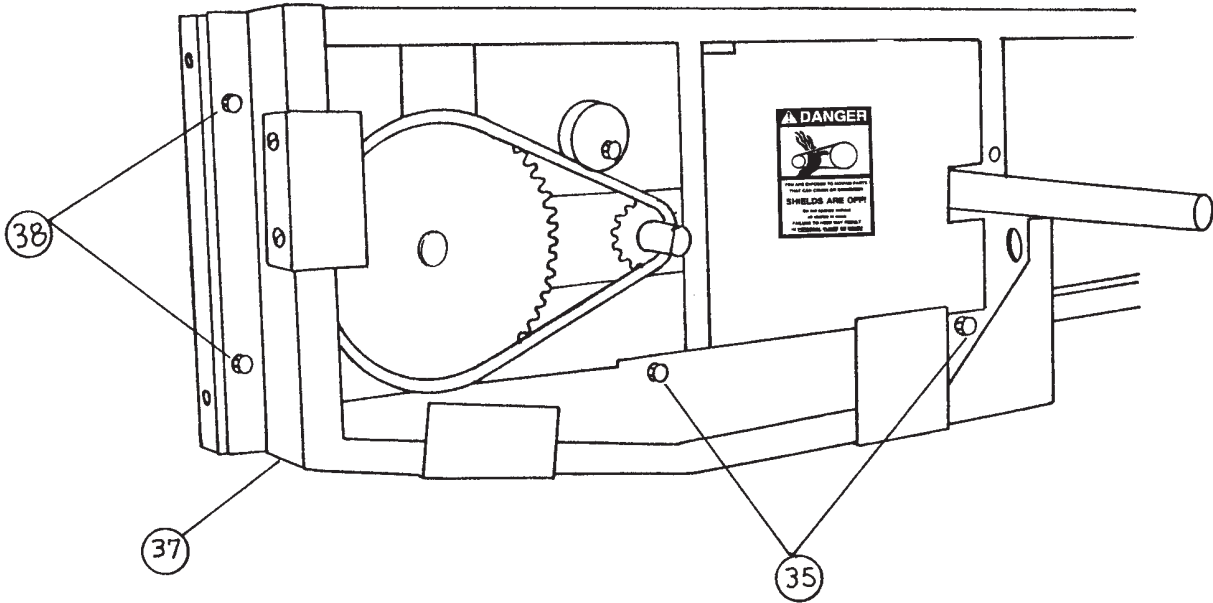
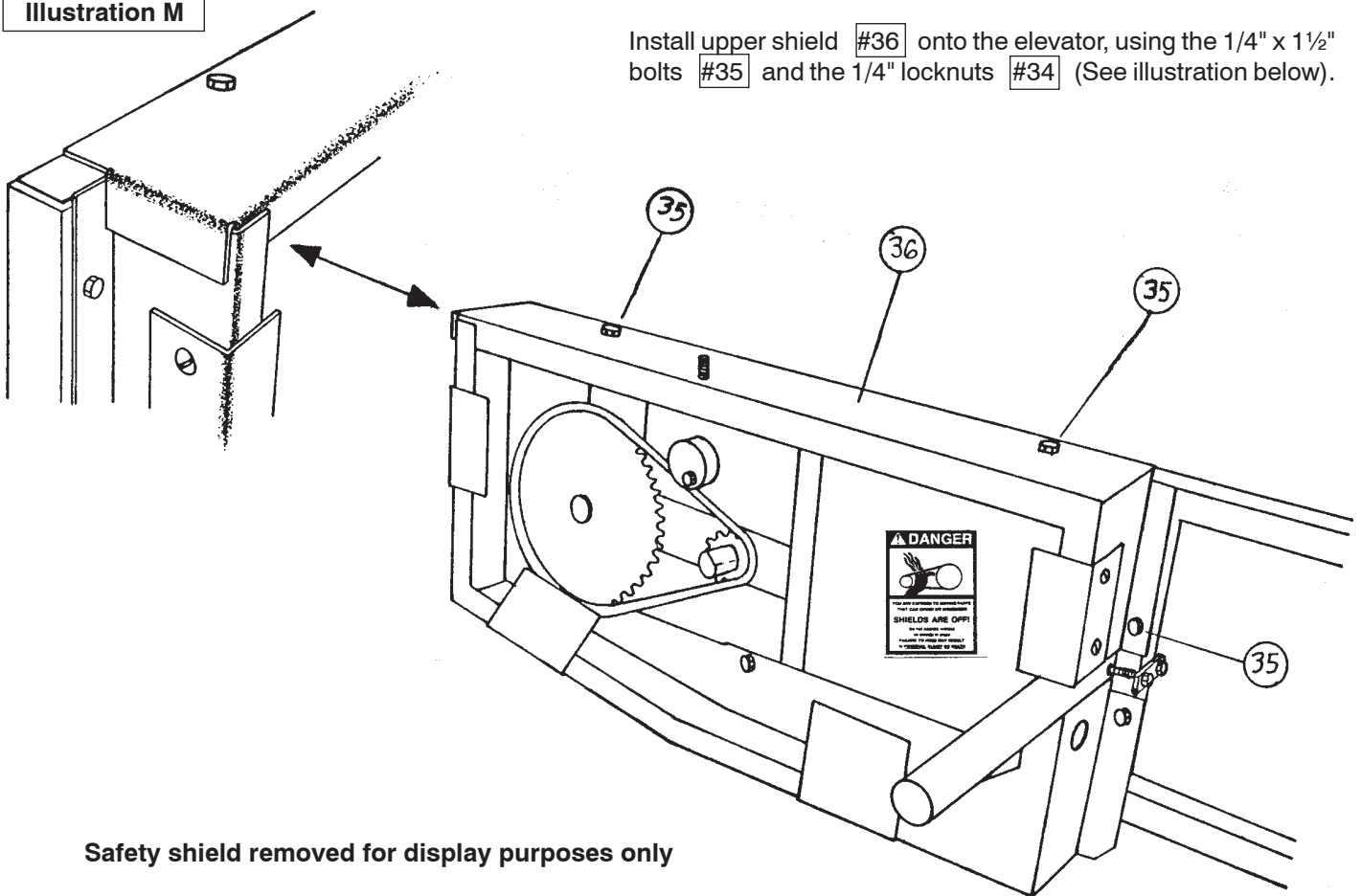

Illustration M

Install upper shield #36 onto the elevator, using the 1/4" x 1 1/2" bolts #35 and the 1/4" locknuts #34 (See illustration below).



Safety shield removed for display purposes only

See pages 12 and 13 for Electric Motor and Horsepower requirements.

Bolt electric motor onto motor mount arms #21 using 5/16" x 1" bolts #22, 5/16" flatwashers #14, 5/16" lockwashers #6 and 5/16" nuts #7. Install electric motor and motor mount arms onto motor mount cross pipe using the AX43 or 4L45 belts #24. It is important that the motor be hung exactly as shown below in order to utilize weight of motor to keep belt snug and to assure proper fitting of shield. Tighten motor mount arm setscrews onto motor mount cross pipe (See illustration below).

Illustration N

Safety shield removed for display purposes only

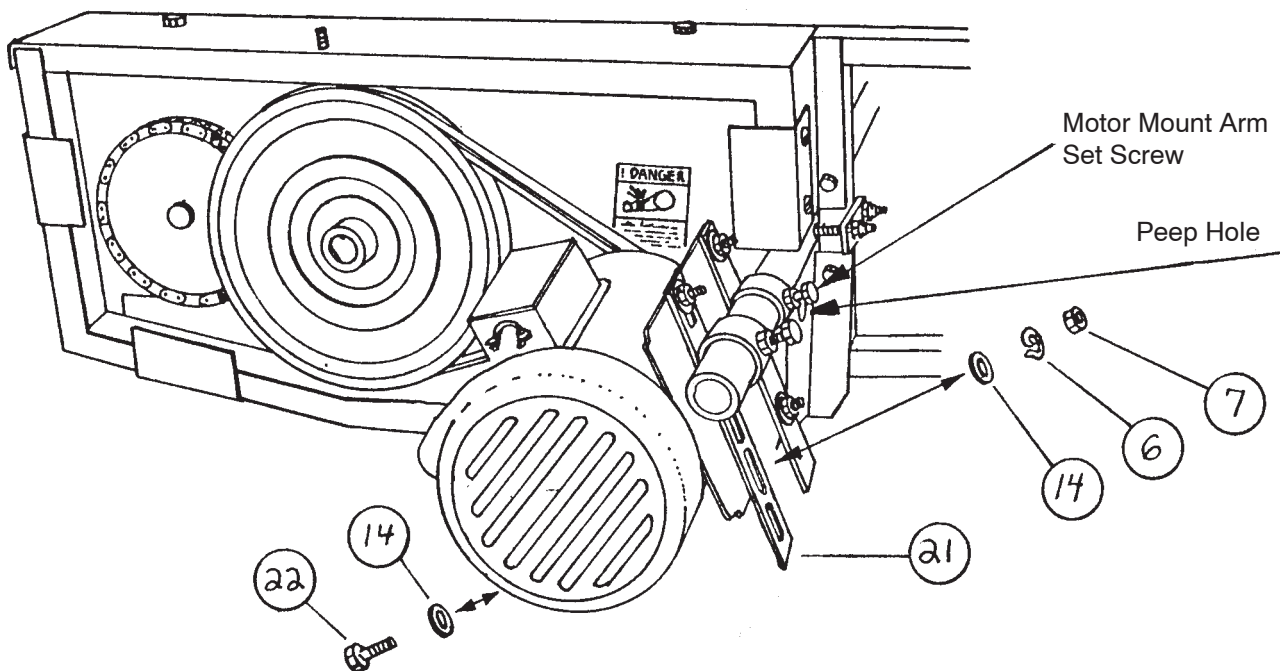

Look through peep hole (under motor mount pipe) in lower shield, and determine the belt is in line. Also check that belt is snugged up but not overtightened. OVERTIGHTENED BELTS WILL CAUSE BEARING AND PULLEY FAILURE.

See pages 12 and 13 for Electric Motor and Horsepower requirements.

Install shield cover #33 onto elevator (See illustrations below).

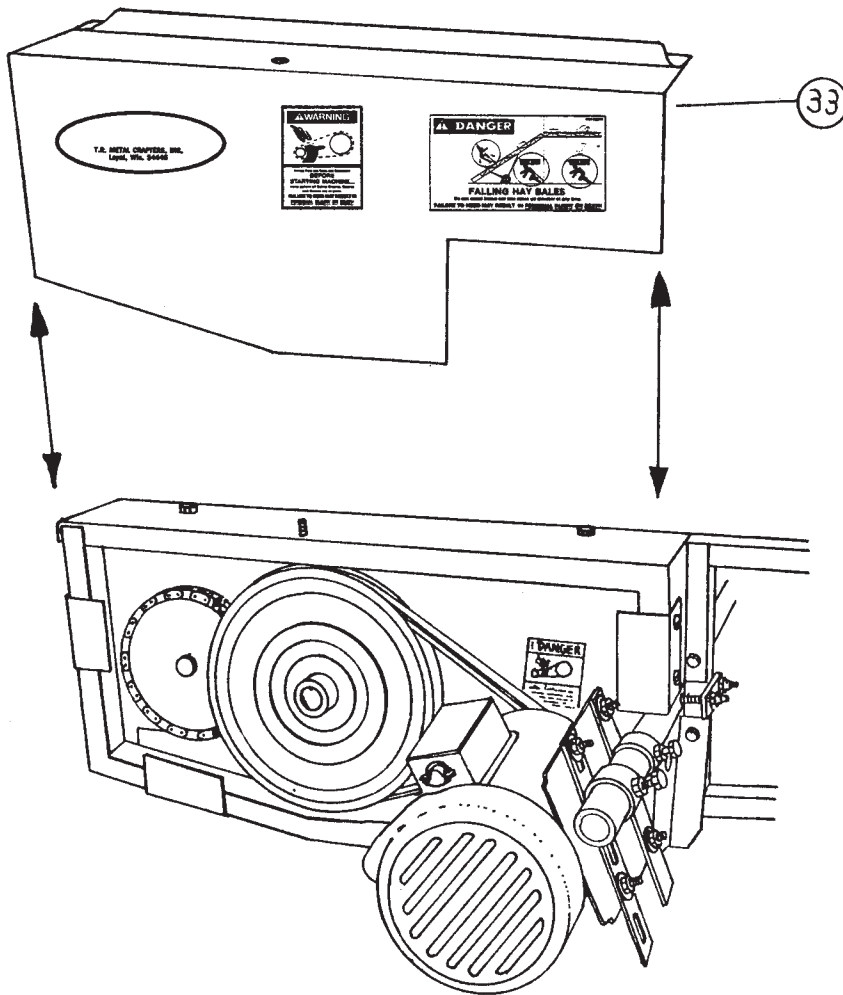
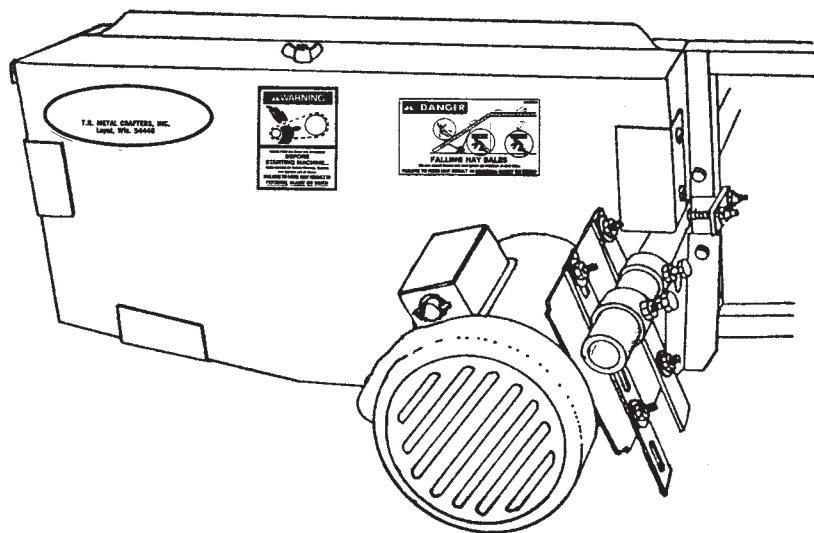

Illustration O

Illustration P



Elevator should be securely fastened to the building during operation or when raised and unattended. This machine is not insulated. Keep away from overhead electrical wires and devices. Electrocutation can occur without direct contact. If shields are lost or missing, contact T. R. Metal Crafters, Inc. for free replacement.

Limited Warranty

T.R. Metal Crafters, Inc. warrants this unit to be free from breakage or malfunctions due to defects in material and/or workmanship under normal farm use and service, for a period of **one-year** from date of original sale. Should such breakage occur within warranty period, the liability of T.R. Metal Crafters, Inc., its employees, agents, authorized distributors, and dealers (hereinafter collectively referred to as sellers) is hereby expressly limited to repairing or, at its option, replacing free of charge at its factory, any part or parts found upon examination by factory to be defective in material or workmanship or both; this is the exclusive remedy. The purchaser is responsible for transportation cost of the equipment for warranty service or for any service call expense. Sellers liability is further expressly limited with respect to components manufactured by others, such as, but not limited to tubes, tires, bearings, detachable link and roller chains, or other trade accessories; to the extent of such warranties as are extended to sellers by these manufacturers. This warranty shall apply only within the boundaries of the continental United States.

Notice of defect shall be furnished in writing to the Seller and to the agent through whom the unit was purchased, disclosing in full all known defects and failure in operation and use. Reasonable time shall be given to the Seller to remedy any such defects and failures.

This warranty is in lieu of all other warranties, expressed (except as set forth within) or implied, including but not limited to warranties of merchantability and fitness for a particular purpose. Manufacturer makes no warranty as to the design, capability, capacity, nor suitability for use of the unit. The obligation and liability of sellers under this warranty does not extend to loss of crops, loss because of delay in harvesting or any expense or loss incurred for labor, supplies, substitute machinery or rental machinery, transportation, or other charges.

Except as provided herein, manufacturer shall have no liability or responsibility to purchaser or any other person or entity with respect to any liability, loss, or damage caused or alleged to be caused directly or indirectly by the unit including, but not limited to, any indirect, special, consequential, or incidental damages resulting from the use or operation of the unit or any breach of this warranty. Notwithstanding the above limitations and warranties, manufacturer's liability hereunder for damages incurred by purchaser or others shall not exceed the price of the unit.

T.R. Metal Crafters, Inc., reserves the right to make changes in design and components or material or to utilize available materials which it deems satisfactory, in order to improve its products. Also, T.R. Metal Crafters, Inc. reserves the right to make changes in the construction or design of any parts without incurring any obligations to install these improvements or changes on previously delivered units.

This warranty shall be void if any part or parts not manufactured or supplied by T.R. Metal Crafters, Inc., are used either in servicing or maintaining the unit, and sellers obligation to repair or replace parts are then voided. This warranty shall be void if in the judgement of T.R. Metal Crafters, Inc., repairs are made in such a manner to affect this unit in a materially adverse manner or if this unit is operated unsafe or while in a state of disrepair. This warranty shall be void if equipment is used for commercial, industrial, lease, rental, custom operation and non-agricultural use. Any damage to this product as a result of misuse, abuse, neglect, accident, improper installation, alteration, repairs (not out own), improper adjustment, accident, damage by fire, act of God, lack of performing required maintenance or any other use contrary to our instructions will void the warranty. This warranty will be void if the product serial numbers are altered, defaced or removed.

If any provision of this limited warranty shall violate any applicable law and is held to be unenforceable, then the invalidity of such provision shall not invalidate any other provisions herein. Applicable law may provide rights and benefits to purchaser in addition to those provided herein.

The terms and conditions of this warranty cannot be altered, modified, or waived by any seller without the expressed, written consent of an officer of T.R. Metal Crafters, Inc.

Notice

T.R. Metal Crafters, Inc., disclaims any liability for the operation of the equipment with the safety shields removed or modified. The nature of this product require that it be operated in a safe way only, and in good repair by qualified persons. Each purchaser, through the process of purchasing this equipment, agrees with T.R. Metal Crafters, Inc., to operate it in a safe manner and in accordance with applicable state and federal laws and agrees to indemnify and hold harmless sellers, from any loss to any person or persons caused by purchaser's failure to do so. Each purchaser further agrees to bring to the attention this notice to each subsequent purchaser, and to obtain his agreement thereto as a condition of resale or transfer.

Important

To make this warranty effective, the Owners "Warranty Registration" card (located inside Owners/Operator's Manual) must be filled out and sent to T.R. Metal Crafters, Inc. within 30-days of purchase.



WARNING

**Read and Understand this manual
*Before Operating***

FAILURE TO HEED COULD RESULT IN PERSONAL INJURY OR DEATH